

**42 SERIES
OFFSET
WHEEL
DISC**



www.monroetufline.com



42/102424SF
SHOWN WITH OPTIONAL
SHOCK FLEX HANGERS
AND
SCRAPER KIT

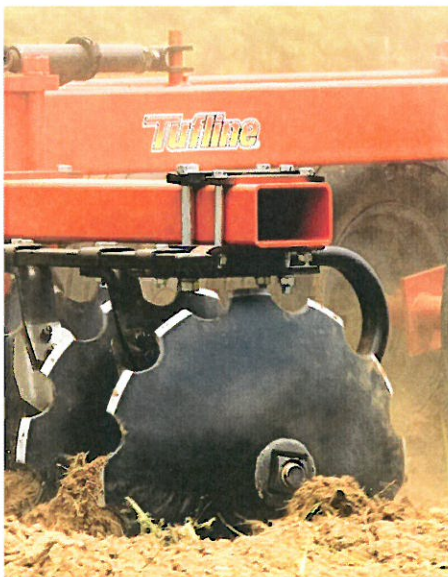

INTRODUCTION

We are pleased that you have chosen a TUFLINE product. To assist you in the assembly and safe operation of your unit, we are providing this booklet. We urge you to read this booklet and thoroughly familiarize yourself with all aspects of safety, assembly, and operation. **Note:** All information contained in this booklet is general in nature and to be used for instructional purposes only. Actual appearance, material and specifications may vary somewhat depending on the specific model being assembled or adjusted.

All references made to the left or right in this booklet are determined by standing at the rear of the machine and facing the direction of travel.

** DISCLAIMER **

Any modifications to this product without the specific permission of TUFLINE are not allowed. Unauthorized modifications beyond the original factory specifications could cause damage to the unit and void the warranty.

** LIMITED WARRANTY **

Monroe Tufline Mfg. Co. Inc., the manufacturer, warrants only to the original purchaser of new TUFLINE equipment that they are free of defects in material and workmanship under normal use and service. This warranty is applicable for six months from date of purchase if for personal use; 90 days for commercial or rental purposes. This warranty does not apply to any equipment which has been improperly assembled or which has been subjected to abuse, negligence, normal wear and tear, modifications, tampering or failure to follow operating instructions, or which has been used for a purpose for which the product is not designed. This warranty does not cover any parts not manufactured by Monroe-Tufline Mfg., Inc.

Claims shall be made to the dealer who originally sold the equipment. Warranty coverage is not valid unless the owner registration card below is completed and returned. All claims must be submitted within 30 days of equipment failure and faulted parts or equipment are subject for return to TUFLINE at TUFLINE'S expense and discretion. Monroe-Tufline reserves the right to make improvements and/or changes in specifications of the product at any time without notice or obligation to modify previously manufactured unit.

No other warranty of any kind whatsoever, express or implied, is made with respect to this sale; and all implied warranties of merchantability and fitness for a particular purpose which exceed the obligations set forth in this written warranty are hereby disclaimed and excluded from this sale.

**Please fill out the registration card below and mail it to:
Monroe Tufline MFG. Attention: Owner Registration
P.O. Box 7755 Columbus, MS 39705**

OWNER REGISTRATION





Name _____ Address/City _____
State _____
Dealer Name _____ City/State _____
Date of Purchase _____ Model No. _____ Serial # _____
Comments _____

TABLE OF CONTENTS



General Safety Precautions.....	1 & 2
Main Frame Assembly.....	3 - 5
Gang Assembly.....	5
Mounting Gangs to Gang Beams.....	8
Front to Rear Gang Shift Recheck.....	8
Spindle & Hub Assembly.....	9
Wheel Carriage Assembly.....	9 & 10
Leveling Assembly.....	10
Operation & Field Adjustment.....	11 & 12
Trouble Shooting Guide.....	13
Maintenance & Service.....	13
Torque Chart.....	14
Optional Equipment.....	15 - 17
Gang Diagrams.....	18 - 33

GENERAL SAFETY PRECAUTIONS





HITCHING:

-  Before hitching, always be certain that the proper hitch pins and retaining pins are available for each hitch position. Use of incorrect parts can allow a partial or complete disconnection which can result in serious property damage and/or personal injury. Direct hitched equipment can be jerked up on top of the tractor and trail type can go in any direction. Blasts of escaping hydraulic fluid can severely injure also.
-  It is very important to throttle the tractor engine to idle speed as the tractor is backed up to the implement and to keep helpers clear.
-  Be sure that the implement is solidly supported to prevent its movement during hitching.
-  Never place hands in possible pinch points such as hitch pin holes.

HYDRAULICS:

-  Watch out for high pressure hydraulic fluid spray and leaks. This can injure your skin or eyes. It will also allow the implement to drop suddenly. Never activate the tractor hydraulic control while not in the tractor seat. Repair all hydraulic leaks immediately.
-  Never allow anyone near the implement when the hydraulic components are being operated. Be sure that the instructions on bleeding air from the system has been followed. Also make sure that the tractor hydraulic system is full of fluid. Air in the system may cause dangerous and erratic operation.

TRANSPORTING:

-  Never allow anyone other than the operator to be on or around the tractor or implement when it is being operated or moved. **NO RIDERS ANYWHERE!**
-  Double check wheel bearings, wheel lugs, wing locks, and transport locks before starting and and every 5 to 10 miles.
-  Use all legally required safety equipment such as slow moving vehicle signs, flashing lights, and front and rear caution vehicles. Obey all area traffic regulations for such transport. Watch for low overheads such as power lines.
-  If the implement is over width, be courteous by periodically pulling off the road and stopping to let long lines of traffic pass.

 Never transport at night without adequate caution lights.

 Never transport at over 20 MPH on highways. On roads where bumps may exist, be aware that heavy implements cannot withstand severe bouncing. Hitting even small bumps at speeds faster than field speed can cause dangerous accidents.

OPERATION:

 Stop the tractor engine and PTO and apply the parking brake before leaving the tractor seat!

 Always operate at reasonable field speeds. Absolute maximum for earth-working implements is 7 MPH. If rocks or other obstructions are present, slow to 1 1/2 to 3 MPH. This is a good speed if the terrain is uneven..

 Use extra caution and slow speeds on steep slopes, near power lines, gullies, and overhanging tree limbs.

ADJUSTMENT AND MAINTENANCE:

 Lower the implement to the ground whenever possible before performing adjustment or maintenance.

 If the implement cannot be lowered, keep all parts of the body clear and block it up securely.

 Do not step on top of implement wheels or walk on the frames. Falls can result in serious injury.

 Never operate implement without all wheels in place.

42 SERIES OFFSET ASSEMBLY

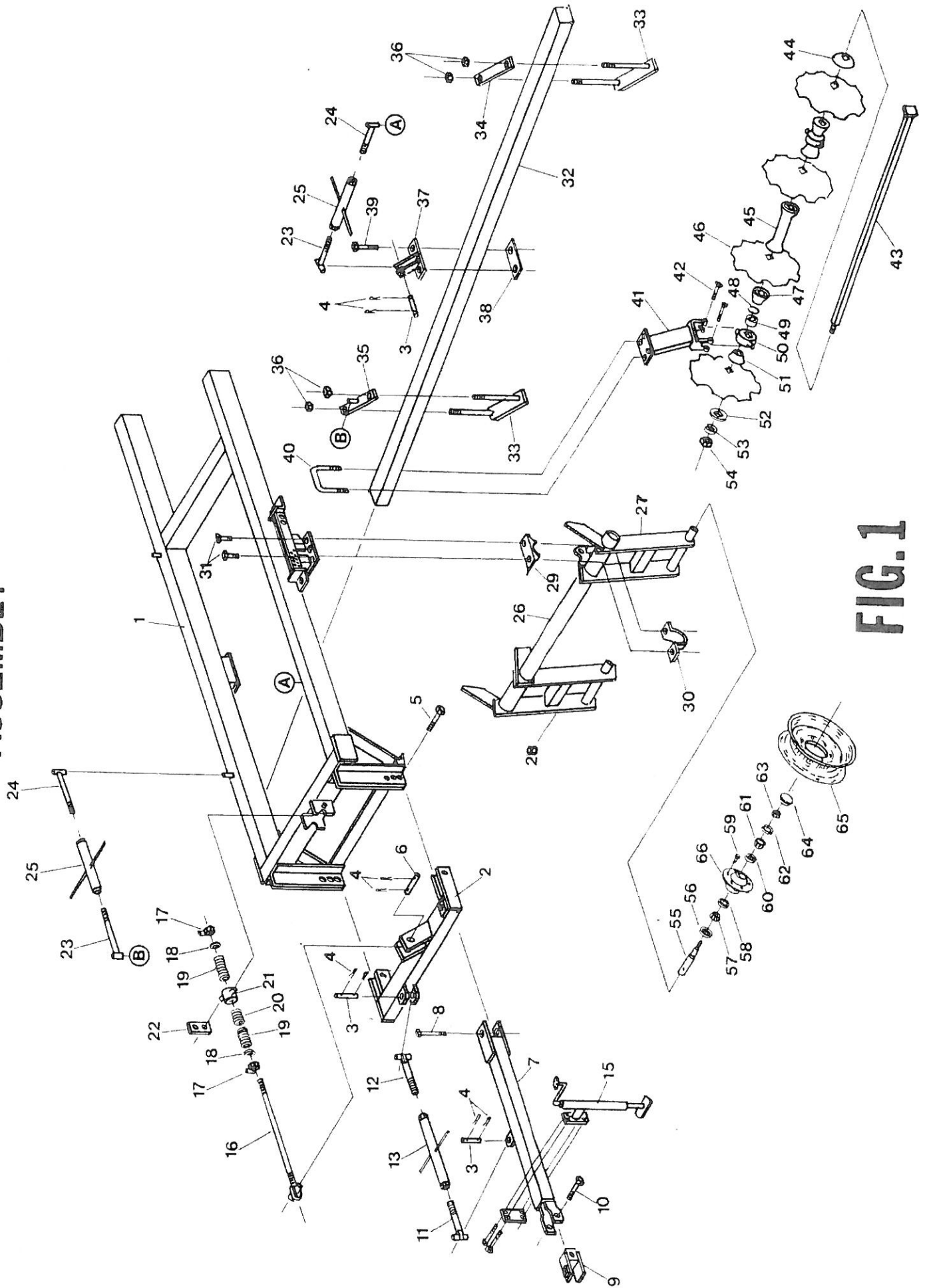

FIG. 1

42 SERIES OFFSET

REF. NO.	PART NO.	DESCRIPTION	REF. NO.	PART NO.	DESCRIPTION
1	11140	Main Frame, 42 Series	36	T-18	Hex Nut, 1 1/8"
			37	11899	GB Tumbuckle Shift Bracket 42 Series
2	11379	Drawbar, 38", 42 Series			
			38	11898	Bottom Clamp Plate, 42 Series
3	T-2661	Pin 1" x 4"			
4	9979	Hair Pin Clip	39	T-736	Hex Bolt, 1/2" x 6" Gr. 2, 42 Series
5	13604	Hex Bolt, 1" x 4", Gr. 5 Plain			
6	T-934	Pin, 1" x 5"	40	12030	U-Bolt, 1", 42 Series
7	11380	Tongue, 56"			
8	T-2662	Hex Bolt, 1" x 6 1/2", Gr. 5	41	12214	Tube Gang hanger, 42 Series
9	T-2665	Clevis			
10	T-772	Hex Bolt, 7/8" x 5", Gr. 5	42	12163	Hex Bolt, 1/2" x 3 1/2", Gr. 5
11	11469	RH Adjusting Screw, 12"	43		Axle, 1 1/2" Sq.
12	11470	LH Adjusting Screw, 12"	44	T-491	Bumper Washer, 1 1/2" Sq.
13	9876	Tumbuckle Barrel, 24"	45	T-103	Spacer Spool, 9" Spacing
				T-104	Spacer Spool, 10 1/2" Spacing
15	T-933	Tongue Jack Assembly	46		Disc Blade
16	11596	Leveling Rod Screw, 31"	47	T-495	End Spacer, 1 1/2" Sq. x 3 7/8" (9" Sp.)
17	T-699	Wing Nut, 1 1/8"		T-106	End Spacer, 1 1/2" Sq. x 4 1/2" (10 1/2")
18	T-698	Flatwasher, 1 1/8"	48	T-729	Snap Ring, 4"
19	T-509	Adjusting Spring, 8 1/2"	49	T-604	Bearing, 1 1/2" Sq. (W211PP3)
20	T-511	Adjusting Spring, 4 1/2"	50	TMD	Trunnion Bearing Housing, 1 1/2" Sq.
21	T-510	Spring Housing	51	T-495	End Spacer, 1 1/2" Sq. x 3 7/8" (9" Sp.)
22	9006	Retainer Strap		T-105	End Spacer, 1 1/2" Sq. x 4 1/2" (10 1/2")
23	11600	RH Adjusting Screw, 9"	52	T-492	End Washer, 1 1/2" Sq.
24	11601	LH Adjusting Screw, 9"	53	T-728	Lockwasher, 1 1/2"
25	10234	Tumbuckle Barrel, 12"	54	T-727	Hex Nut, 1 1/2"
26	11315	Wheel Carriage Axle, 53 1/2" (42)	55	T-564	Spindle, 1 5/8"
			56	T-576	Seal, 1 1/2"
27	11313	LH Wheel Arm	57	T-575	Inner Wheel Bearing, 1 1/4" LM67048
28	11312	RH Wheel Arm	58	T-583	Inner Wheel Bearing Cup
29	T-5746	Wheel Carriage Bearing Top, 4 1/2"	59	T-562	Lug Stud, 1/2" x 1 1/2"
30	T-5745	Wheel Carriage Bearing Bottom, 4 1/2"	60	T-582	Outer Wheel Bearing Cup
31	9192	Hex Bolt, 5/8" x 2 1/2", Gr. 5	61	T-574	Outer Wheel Bearing, 3/4"
32		Gang Beam	62	T-603	Spindle Washer, 3/4" ID x 1 1/2" OD
33	11389	Bottom Clamp Plate, 42 Series	63	T-567	Slotted Nut, 3/4"
			64	T-577	Hub Cap
34	11390	Top Clamp Plate, 42 Series	65	T-612	Wheel Rim (5 Hole)
			66	T-566	Hub Only (Available in Assembly Only)
35	11392	Top Clamp Plate w/TB Stud 42 Series	58,59, 60,66	T-572	Hub Assembly
			55,62, 63	T-565	Spindle Assembly, 1 5/8"

MAIN FRAME ASSEMBLY

1. Select an area large enough to allow movement of the gangs around the main frame.
2. Support the main frame on solid supports at A, B, C, and D, Fig. 2, to a height that will allow the gangs to be moved underneath the gang beams for mounting.
3. Place the gang beams, Ref 32, Fig. 1, underneath the frame between the stop lugs that are welded at the front and rear of the left side member. Locate the right end of the front gang beam approximately 21" behind the front cross member of the main frame and the rear gang beam 17" behind the rear cross member as shown in Fig. 2. This will provide about an 18 gang angle.
4. Clamp both front and rear gang beams loosely under the frame using the bottom clamps, Ref. 33, Fig. 1, and the top clamp plates, Ref. 35, Fig. 1, with the turnbuckle anchor stud welded on for the right hand side of the harrow. The plain top clamp, Ref. 34, is for the left hand side.

GANG ASSEMBLY

1. Refer to Fig. 3 and assemble your gangs as shown. Use the largest diameter end spacer, Ref. 6, at the rear or convex side of the disc as shown and the smaller diameter spacer, Ref. 12, at the front or concave side of the disc.
2. The small end of the spacer spool, Ref. 5, is placed against the front or concave side of the disc blade.
3. Before tightening, be sure that the square hole in the end of the disc blade, Ref. 4, and the end washer, Ref. 3, are aligned with the square of the axle, Ref. 11. Do not install lockwasher yet.
4. Tighten the lock nut until it is snug and then remove it while holding the end of the blade to prevent its movement. Recheck the alignment and be sure the axle square is about 1/4" back inside of the end washer or the gang may not tighten properly before the nut runs out of threads. If the threads extend too far, a special square hole spacer washer is available to take up any slack. If the square fails to get through the disc blade, your axle is too short.
5. Assemble the lockwasher and lock nut and tighten snugly. Roll the gang about 1 revolution while bumping the disc blades sideways to make them vibrate and more or less self center.
6. Tighten the nut to 1550 ft. lbs. on 1 1/2" axle. See torque chart.

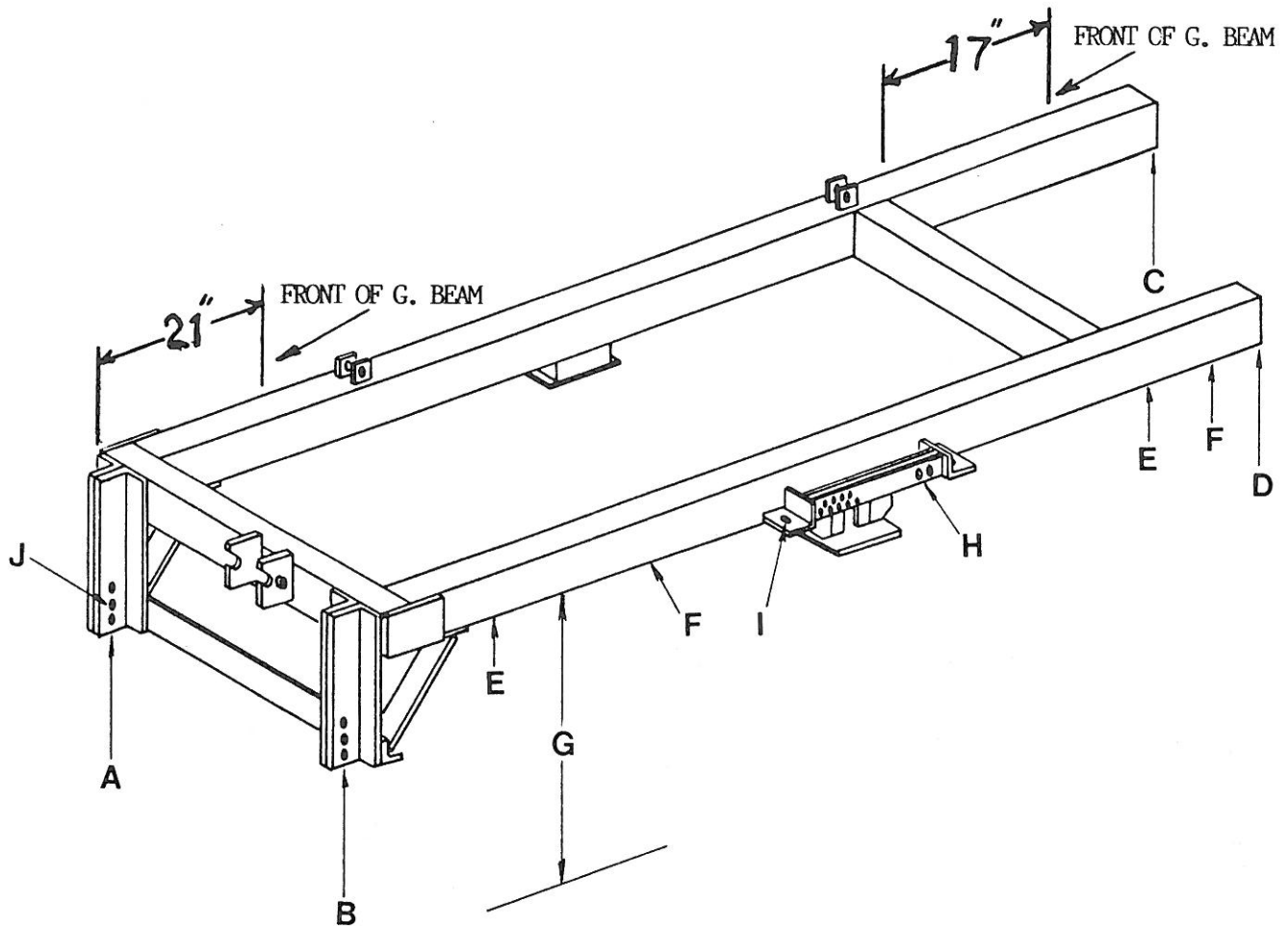

FIG. 2

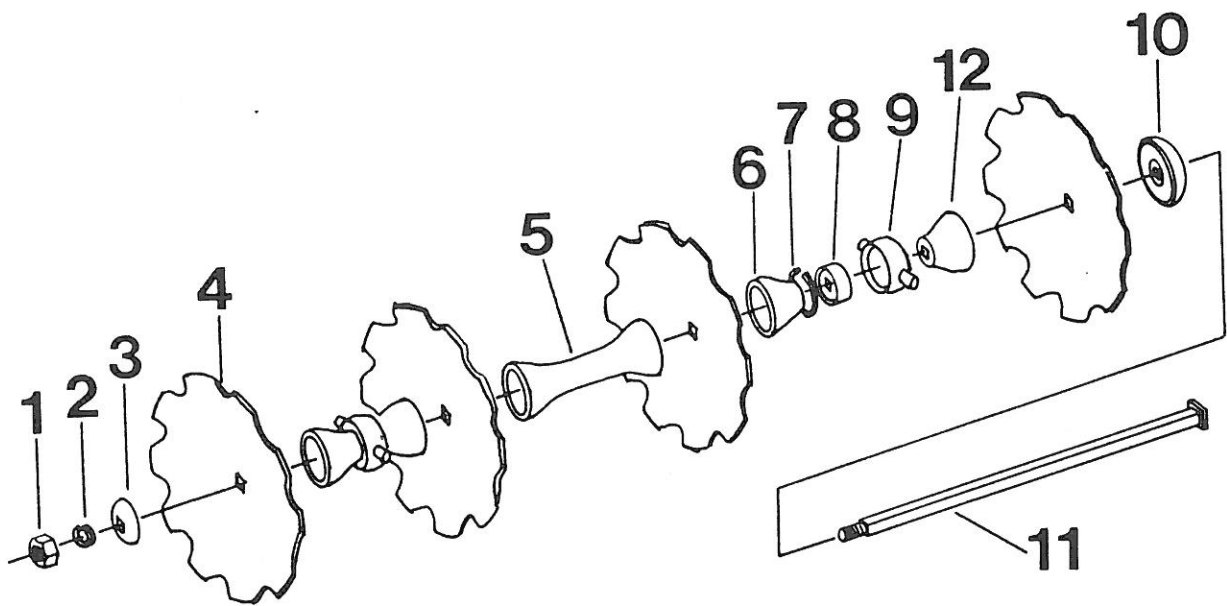

FIG. 3

TUBE HANGER ASSEMBLY DIAGRAM

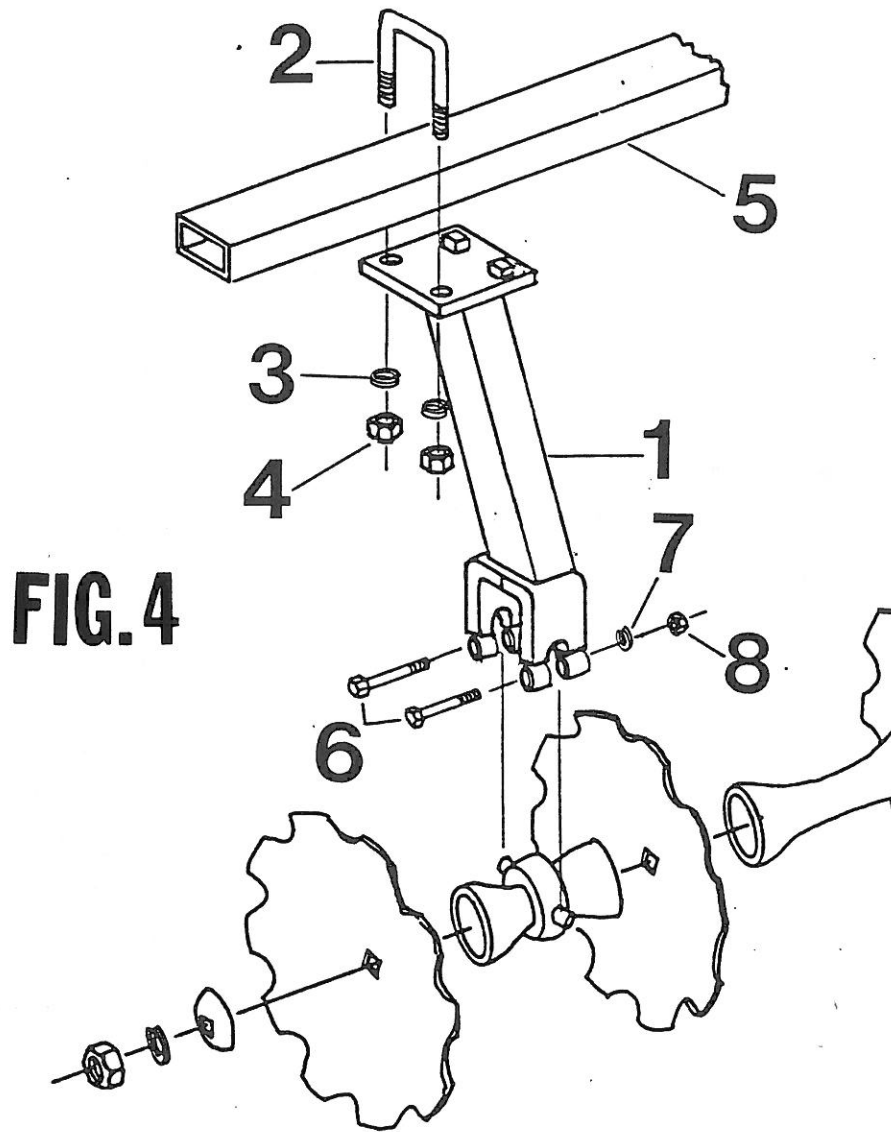

FIG. 4

<u>REF. NO.</u>	<u>DESCRIPTION</u>
1	TUBE HANGER, 1 1/2" AXLE
2	U-BOLT, 7/8"
3	LOCKWASHER, 7/8"
4	HEX NUT, 7/8"
5	GANG BEAM
6	HEX BOLT, 1/2" x 3 1/2", GR. 5
7	LOCKWASHER, 1/2"
8	HEX NUT, 1/2"

MOUNTING GANGS TO GANG BEAMS

1. Refer to the correct gang diagram for your model, pages 18 - 33, and roll the gangs into place underneath the gang beams as indicated.

⚠ CAUTION: Keep clear from underneath the frame and handle sharp disc blades carefully.

Allow the same spacing between the gangs as between each blade. You may have to slide the gang beams so that the ends will line up with the outer hangers on the gangs.

2. Mount the tubular gang hangers onto the disc gangs at the bearing trunnion housing using the 1/2" x 3 1/2" Gr. 5 hex bolts, Ref. 6, Fig. 4. Attach the hangers to the gang beams with the 7/8" U-bolt, Ref. 2, and loosely tighten the lockwasher and hex nut, Ref. 3 & 4. Align the gangs and check the blade spacing between the gangs and then securely tighten the U-bolts.

FRONT TO REAR SHIFT RECHECK

1. Refer to Fig. 5 and measure from the top center edge of the blade on the left hand side of the harrow to the main frame a distance of A and B as shown in Fig. 5. These distances are specified on the gang diagram used for arranging the gangs. Distance A should be about 4" to 5" more than distance B for 9" spacing and 5" to 6" for 10 1/2" spacing.
2. Screw the front and rear lateral turnbuckles, Ref. 25, Fig. 1, out about 2 1/2" on each end and attach one end to the main frame as shown in Fig. 1. Mount the turnbuckle anchor clamp, Ref. 37, Fig. 1, to the gang beam and to the other end of the turnbuckle and tighten securely to both.

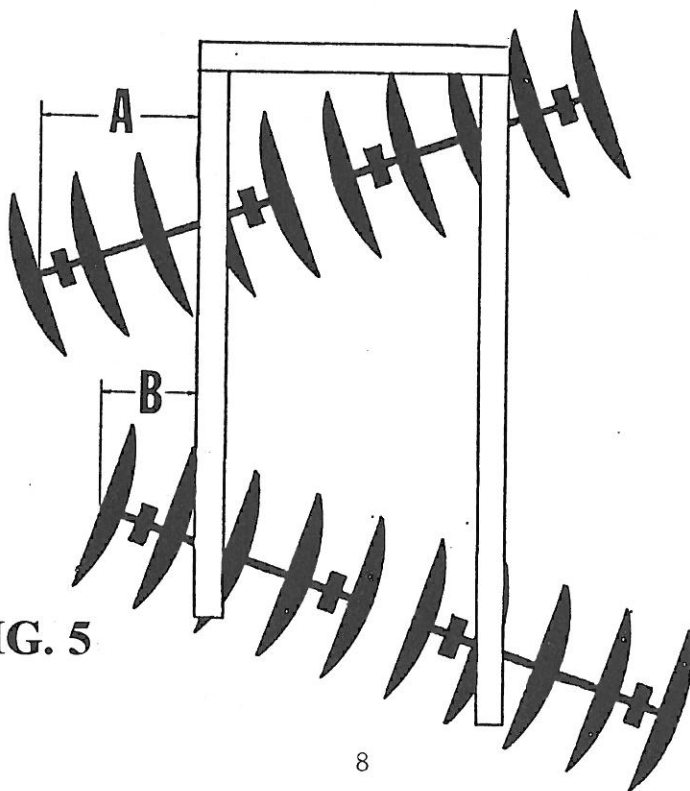
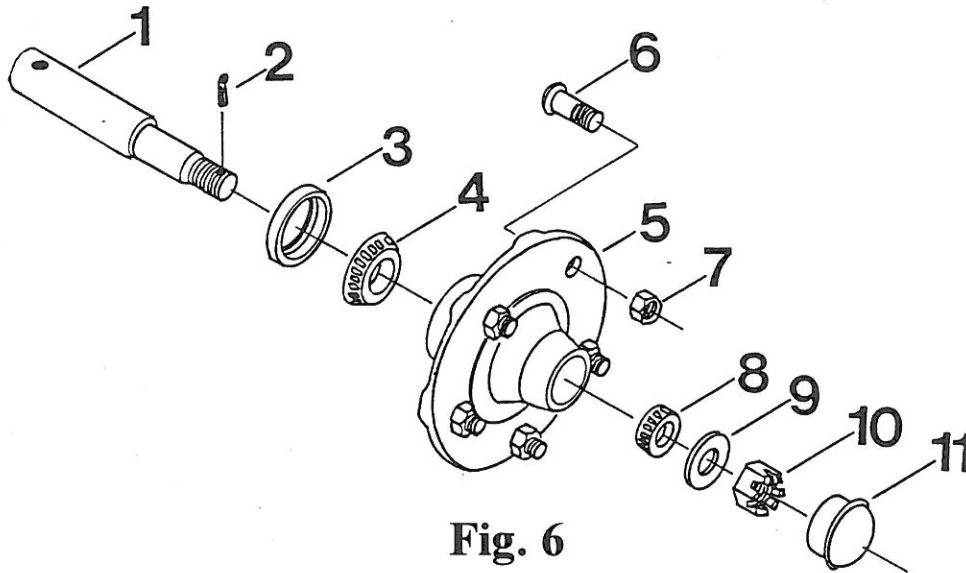

FIG. 5

HUB & SPINDLE ASSEMBLY

1. Refer to Fig. 6. Using utmost cleanliness, pack the wheel bearings with grease and stuff the hub.
2. Install the large bearing, Ref. 4, and the seal, Ref. 3, into the hub with the seal lip toward the hub.
3. Next install the smaller bearing, Ref. 8. Insert the spindle, Ref. 1, through the hub and then place the flat washer, Ref. 9, and slotted nut, Ref. 10, onto the spindle.
4. Tighten the nut until the hub is very hard to turn and then back off one slot on the nut. Install the cotter pin, Ref. 2.

Note: Attention to initial assembly and proper maintenance of hub, spindle, and wheel is very important for trouble free operation. Farm implement wheel bearings should not be as free as automotive bearings.



WHEEL CARRIAGE ASSEMBLY

1. Refer to Fig. 7 and 8. Position the entire wheel carriage, Fig. 7, under the main frame with the wheel legs extending to the rear and the depth control arms, L & R, Fig. 7, inserted into the depth control quadrants, Ref. H, Fig. 2. Before lifting the wheel carriage up to the frame install the wheel carriage bearing sets, Ref. 29 & 30, Fig. 1, and loosely tie together with very light wire.

2. Lift wheel carriage and bolt into place between the bearing sets with the 5/8" x 2 1/2" Gr. bolts. After tightening the bolts, check to see if the carriage will rotate by hand. If it won't, insert a shim between the bearing halves and reclamp until it rotates.

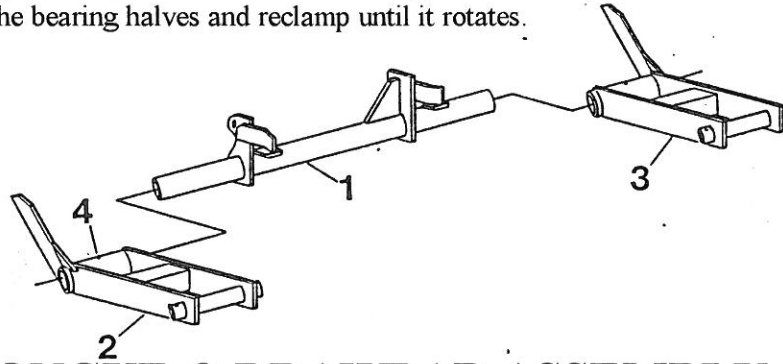

TONGUE & DRAWBAR ASSEMBLY

1. Select the hole position in the main frame front hitch angle, Ref. J, Fig. 2, that will best suit your tractor and operating adjustment needs.
2. Generally, the lower hole can be used for tractors with drawbars not over 19", but the upper hole should be used for higher drawbar tractors.
3. Attach the drawbar with the 1" x 3 1/2" Gr. 5 hex bolts, Ref. 2, Fig. 8, in the hole you have selected on the main frame. Next attach the tongue to the drawbar with the 1" x 6 1/2" Gr. 5 hex bolt, Ref. 2, Fig. 9. Tighten this bolt until the tongue yoke begins to clamp on the drawbar. The tongue turnbuckle will then be mounted on the tongue and drawbar with the 1" x 4" pins, Ref. 3, Fig. 8 & 9. Secure the pins with 3/16" x 1 1/2" cotter pins, Ref. 4.

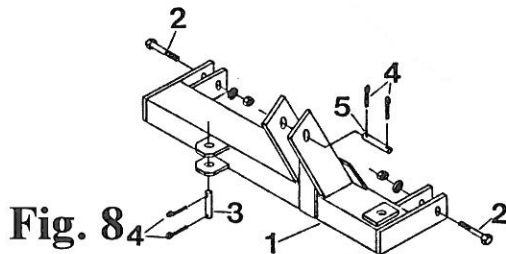
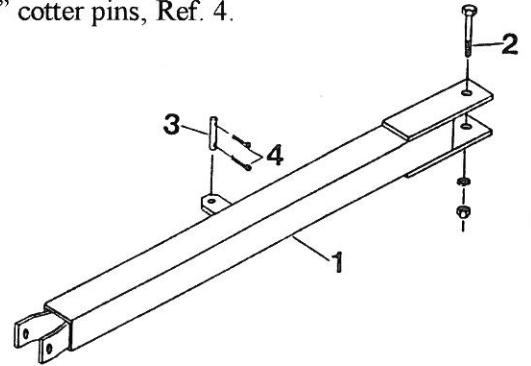
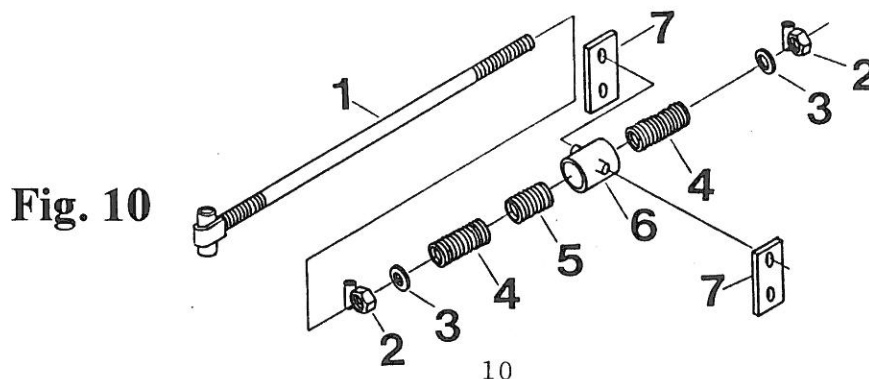

Fig. 9



LEVELING ASSEMBLY

1. Position the leveling assembly as shown in Fig. 1. Pin the leveling rod screw, Ref. 16, into the mounting ears on the drawbar with the 1" x 5" pin, Ref. 6. Lock the trunnion, Ref. 6, Fig. 10, into place on the main frame with the retainer straps, Ref. 7, Fig. 10.



OPERATION & FIELD ADJUSTMENT

HITCH & LEVELING ADJUSTMENT:

1. When attaching to the tractor, the hydraulics should be connected as soon as the tractor is close enough to hitch.

 Block harrow's wheels to prevent rolling in either direction and have everyone clear of the machine. Activate the cylinder and raise the harrow to transport position. The harrow will balance on the wheels and hitch easily. Insert the transport pins in front of the depth control arm in hole H, Fig. 2. Use hole I for storage.

2. Lower the harrow slowly. The rear gang should touch the ground when the front is about 1 1/2" above it. If it doesn't, adjust the leveling control. Screw the nuts, Ref. 7, Fig. 1, down toward the tongue to lower the front and up to lower the rear. Total length of spring between nuts, Ref. A, Fig. 10, should be approximately 20" or the springs half compressed to properly stabilize operation and transport of the harrow.

GANG ALIGNMENT FIELD CHECK:

1. Drive absolutely straight ahead while lowering the disc until the blades begin to lightly scratch the soil surface. The marks made by the rear blades should be as described in "Front to Rear Shift Check" on page 8, and Fig. 5. Adjust the lateral turnbuckles if needed.

PLOWING DEPTH:

1. Pull forward with the depth and transport pins in storage until right front blades reach the desired plowing depth and then insert the right hand pin in front of the depth control arm.
2. Continue to pull forward until the left-hand side reaches the same depth and place the pin in the closest hole in front of the left-hand depth control arm. In some cases, it is necessary to pin the right hand side up more if the left side won't cut as deep.

CAUTION: Insertion of the pin behind the depth control arm at any position will cause Damage to the wheel control system.

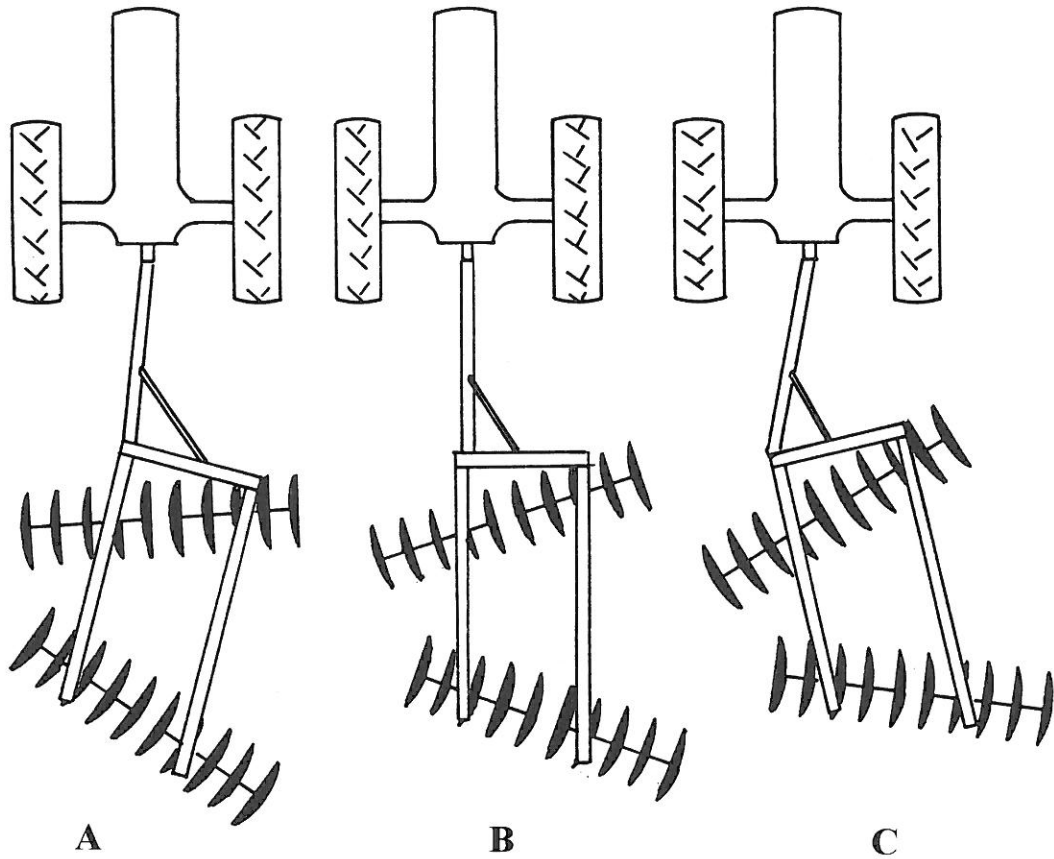

TRACKING TO LEFT

1. Usually causes severe side draft.
2. Front gang won't break the soil and the rear skips.

CAUSE OR SOLUTION

1. Tongue set too far to the left.
2. Not enough pressure on the rear. See "Leveling."
3. Too much angle in front gangs and not enough in the rear gangs.

CORRECT TRACKING

1. Accomplish this by making one adjustment at a time from error at A or C.
2. If the harrow is level, try the tongue first.
3. Check front and rear penetration next.

TRACKING TO RIGHT

1. Front gang plows but skips and the rear gang does almost nothing.
2. Tongue may be too far to the right because of effort to cut the left tractor wheel track out. Tongue could be over adjusted to reduce side draft.

CAUSE OR SOLUTION

1. Lower front to apply more pressure.
2. Swing the tongue to the left slightly and/or decrease rear gang angle.

TROUBLE SHOOTING GUIDE

PROBLEM	CAUSE OR SOLUTION
Side draft and/or penetration not uniform	See Fig. 11 and comments.
Furrow not being filled on the left side	Harrow tracking too far to the right as in Fig. 11. Right front plowing too deep and rear not deep enough.
Bed left on right hand side of harrow	Right front plowing too deep or condition A, Fig. 11.
Furrow on left and right side when plowing 2 ways	Use an outrigger blade 6" smaller than the diameter of the disc blade. Rear gangs may be plowing too deep

MAINTENANCE & SERVICE

 **CAUTION:** Always park equipment on the ground or on blocks.

1. Lubricate wheel carriage bearings once a week.
2. Lubricate all turnbuckles thoroughly when first assembled and twice per season thereafter.
3. Lubricate wheel bearings thoroughly about every 200 hours and check adjustments.
4. Optional regreasable gang bearings should be lubricated about every 200 hours or 2 or 3 times per season. Special care toward cleanliness of grease fittings and grease must be taken. Dirt pumped into housings is much worse than not lubricating.
5. Check gang axle tightness after first 10 hours and about every 200 hours afterward.

TUFLINE BOLT TIGHTENING TORQUE CHART

*A = Ft. lbs. B = Lbs. on 7' Lever C = Kilograms (Metric)

SIZE	DESCRIPTION	SAE GRADE								
		GRADE 2			GRADE 5			GRADE 8		
		A	B	C	A	B	C	A	B	C
1/2"	Hex Bolt	45		6	75		10	100		15
5/8"	Hex Bolt	90		12	150		20	200		30
3/4"	Hex Bolt	150		21	250	36	35	350	50	50
7/8"	Hex Bolt	165		30	350	55	50	550	80	75
7/8"	Gang Axle				250	36	35			
1"	Hex Bolt	245	43	40	580	85		825	120	110
1 1/8"	Hex Bolt	474	68	65	780	115	80	1300	185	175
1 1/8"	Gang Axle				500	72	67			
1 1/2"	Hex Bolt	1050	150	145	1700	240	230	2900	415	395
1 1/2"	Gang Axle (Thread each end)				1000	143	133			
1 1/2"	Gang Axle (with head)	1200	172	165						

** Torque wrenches may not be available for over 300 ft. lbs. Use a 7' lever and spring scales

OPTIONAL EQUIPMENT

SCRAPERS

1. Place the proper length scraper bars and the correct number of left or right hand scraper arm assemblies near each gang for mounting on the gang beam.
2. Refer to Fig. 11 for this assembly. Mount the scraper bar mounting bracket, Ref. 1, underneath the gang beam, and place the clamp plate, Ref. 2, on top of the gang beam with the $5/8'' \times 5''$ hex bolt for $3'' \times 5''$ gang beams or $5/8'' \times 5''$ hex bolt for $4'' \times 6''$ gang beams. Note the scraper bars are mounted on the rear of the gang beam.
3. Place the scraper bar, Ref. 13, on top of the mounting bracket and use the $1/2'' \times 2 1/2''$ hex bolt, Ref. 6, and the one hole clamp, Ref. 11, to secure the bar in place. Tighten the $1/2''$ flange nut, Ref. 7.
4. After bolting the bars in place, add the arm and blade assemblies, Ref. 17, to the bars using the two hole clamps, Ref. 12, and two $1/2'' \times 2 1/2''$ hex bolts, Ref. 6. Position each scraper as near to the disc blade as possible without actually it. Spinning the gang after mounting the scrapers is recommended to prevent dragging or binding of the gang. After all scrapers are correctly adjusted, tighten each bolt to approximately 50 ft. lbs.

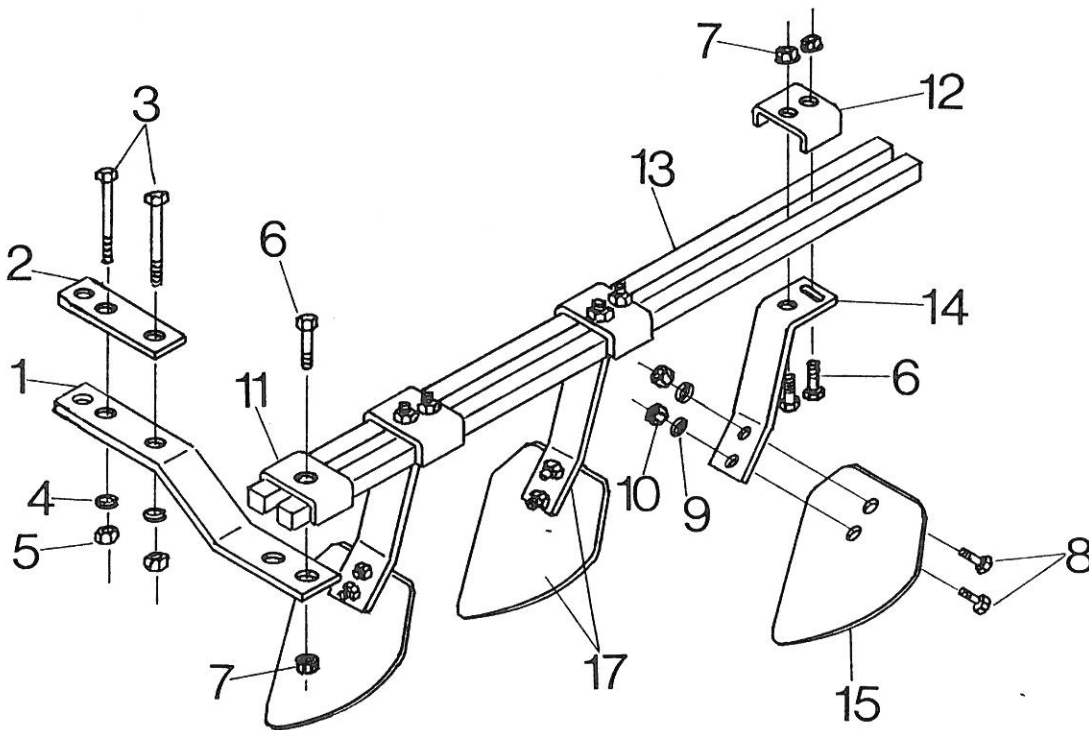
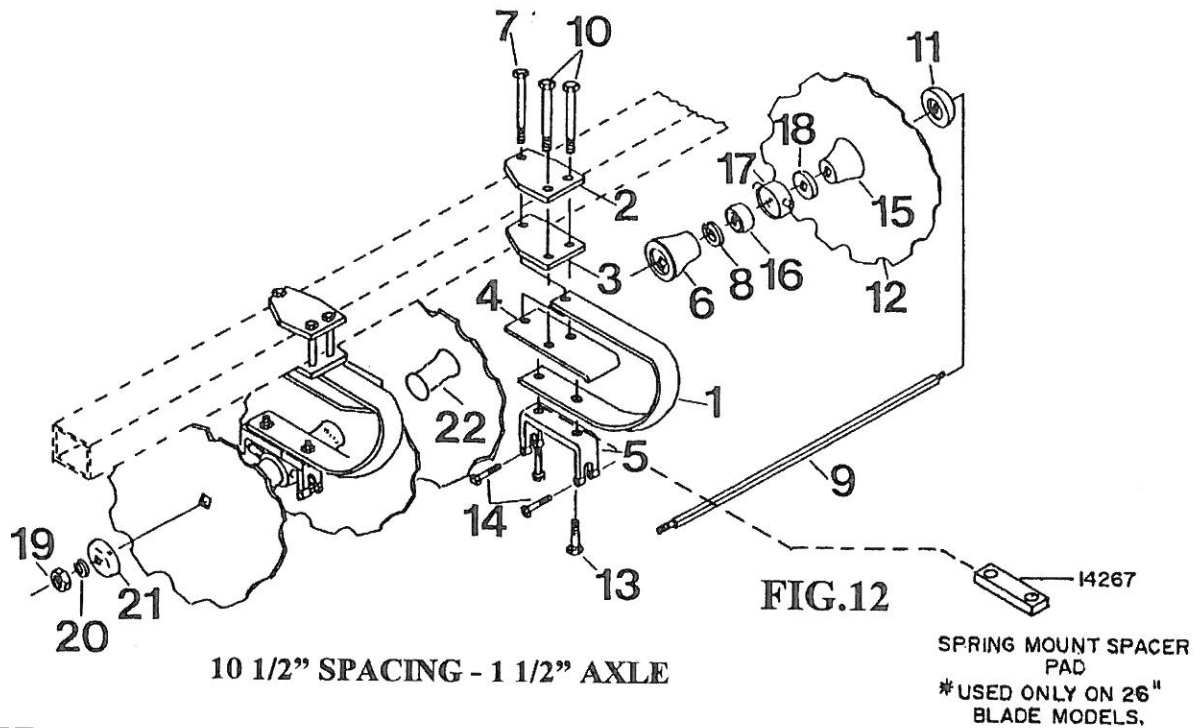

FIG. 11

SHOCK FLEX GANGS

These gangs provide limited cushioning when obstructions are present. Although this added protection is present with these gangs, do not disregard the standard safe operating procedures that are outlined in the general safety instructions.

1. For gang assembly, refer to Fig. 12 & 13. Attach the trunnion mounting weldment, Ref. 5, to the spring hanger shank, Ref. 1, with the two 3/4" x 3" Gr. 5 hex bolts.
2. Place the spring mount top plate, Ref. 2, on top of the gang beam and the alignment plate, Ref. 3, underneath the gang beam. Place the 7/8" x 7" and 5/8" x 7" hex bolts (3" x 5" gang beam) or the 7/8" x 8" and 5/8" x 8" hex bolts (4" x 6" gang beam), Ref. 7 & 10, through these two plates. Pull the shank with the mounting weldment, Ref. 1, up to the alignment plate. Under the shank place the bottom plate, Ref. 4, and tighten bolts in order to clamp the shank between the plates.



REF. NO.	PART NO.	DESCRIPTION	REF. NO.	PART NO.	DESCRIPTION
1	9553	Spring Hanger Shank	11	T-491	Bumper Washer, 1 1/2" Sq.
2	10393	Spring Mount Top Plate 4 x 6	12		Disc Blade, 1 1/2" Sq.
3	10394	Alignment Plate 4 x 6	13	T-763	Hex Bolt, 3/4" x 3" Gr. 5
4	10392	Bottom Plate 4 x 6	14	12163	Hex Bolt, 1/2" x 3 1/2" Gr. 5
5	12159	Trunnion Mounting Weldment	15	T-106	End Bearing Spool - Front
6	9559	Offset Bearing Spacer	16	T-604	Bearing, 1 1/2"
7	10483	Hex Bolt 7/8" x 8" Gr.5 4 x 6	17	TMD	Trunnion Bearing Housing
8	T-729	Snap Ring, 4"	18	9560	Offset Brg Spacer - Rear
9		Axle, 1 1/2" Sq.	19	T-727	Hex Nut, 1 1/2"
10	T-753	Hex Bolt 5/8" x 8" Gr.5 4 x 6	20	T-728	Lockwasher, 1 1/2"
			21	T-492	End Washer, 1 1/2"
			22	T-104	Spacer Spool, 10 1/2"

*3/4" x 4" Gr.5 (#9859)
IS USED ON SHOCK FLEX
GANGS W/26" BLADES.

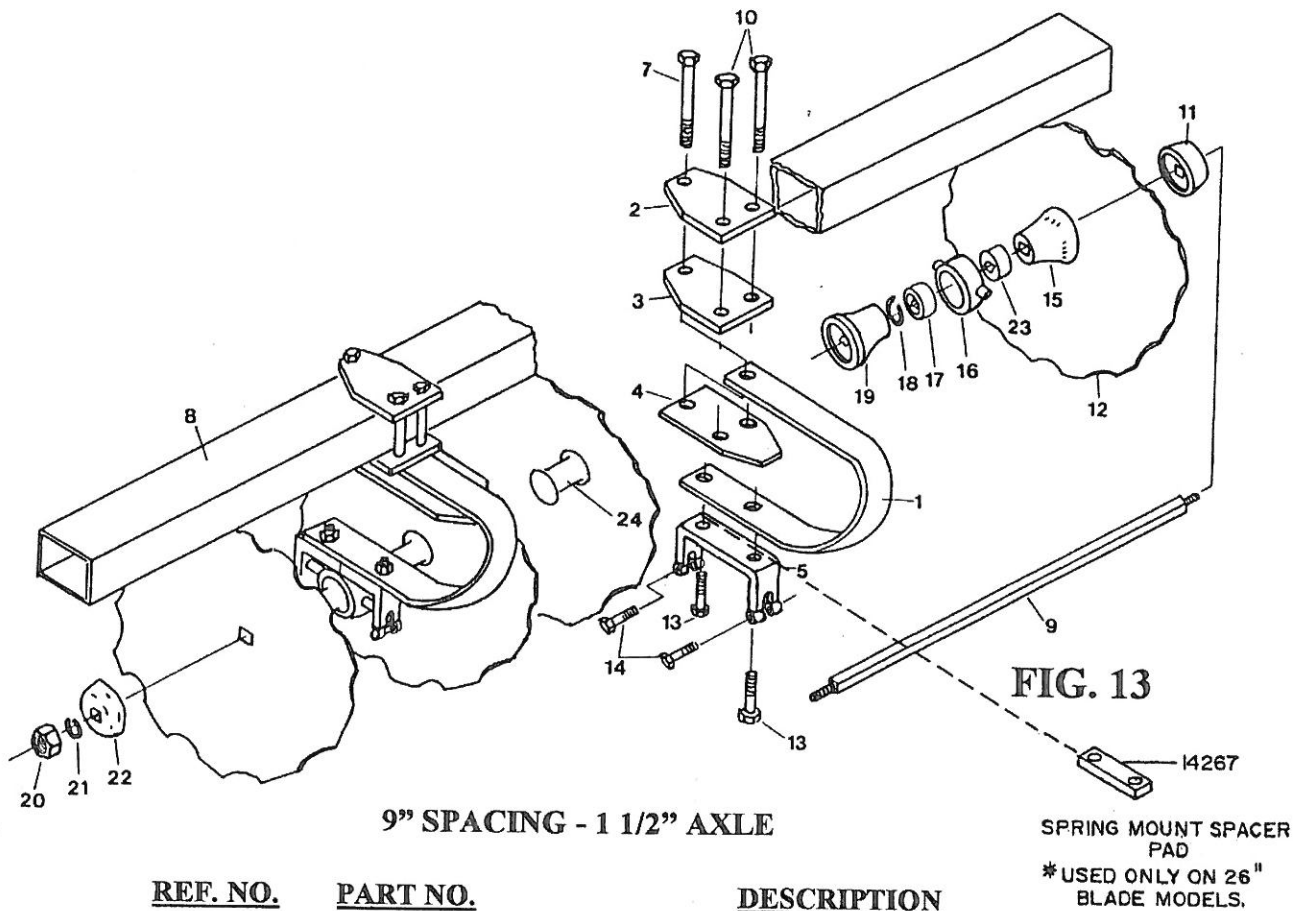

<u>REF. NO.</u>	<u>PART NO.</u>	<u>DESCRIPTION</u>
1	9553	Spring Hanger Shank
2	10393	Spring Mount Top Plate 4" x 6" Gang Beam
3	10394	Spring Mount Alignment Plate 4" x 6" Gang Beam
4	10392	Spring Mount Bottom Plate 4" x 6" Gang Beam
5	12159	Trunnion Mounting Weldment
7	10483	Hex Bolt 7/8" x 8" Gr. 5 4" x 6" Gang Beam
8		Gang Beam
9		Axle, 1 1/2" Sq.
10	T-753	Hex Bolt 5/8" x 8" Gr. 5 4" x 6" Gang Beam
11	T-491	Bumper Washer, 1 1/2" Sq.
12		Disc Blade, 1 1/2" Sq.
13	T-763	Hex Bolt, 3/4" x 3" Gr. 5
14	12163	Hex Bolt, 1/2" x 3 1/2" Gr. 5
15	T-108	End Spacer, 1 1/2"
16	TMD	Trunnion Bearing Housing
17	T-604	Bearing, 1 1/2"
18	T-729	Snap Ring, 4"
19	T-107	Offset Bearing Spacer, Front
20	T-727	Hex Nut, 1 1/2"
21	T-728	Lockwasher, 1 1/2"
22	T-492	End Washer, 1 1/2"
23	10639	Offset Bearing Spacer, Rear
24	T-103	Spacer Spool, 1 1/2" Sq. x 9"

*3/4" x 4" Gr.5(#9859)
IS USED ON SHOCK FLEX
GANGS W/26" BLADES.

FRONT

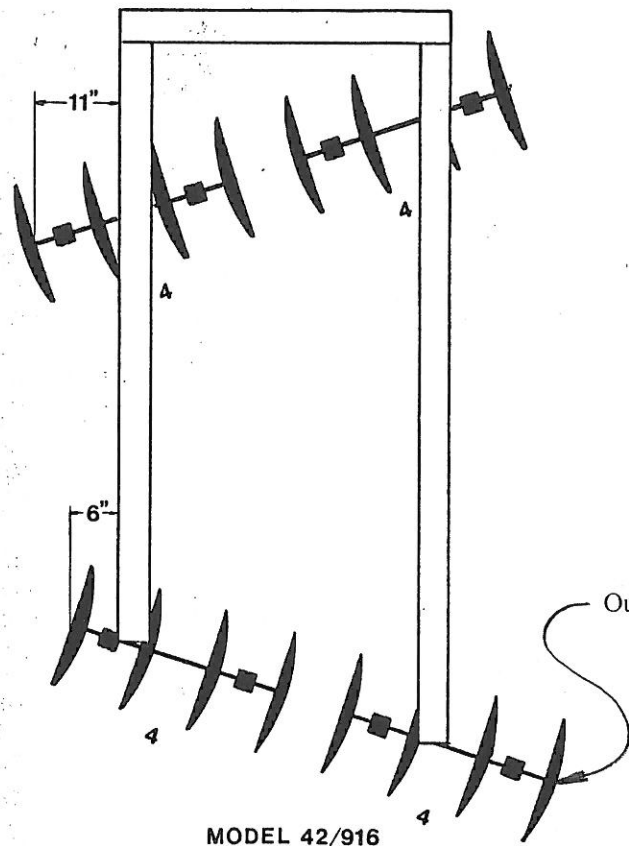

63" GANG BEAMS

MODEL 42/916
TUBE HANGERS

FRONT

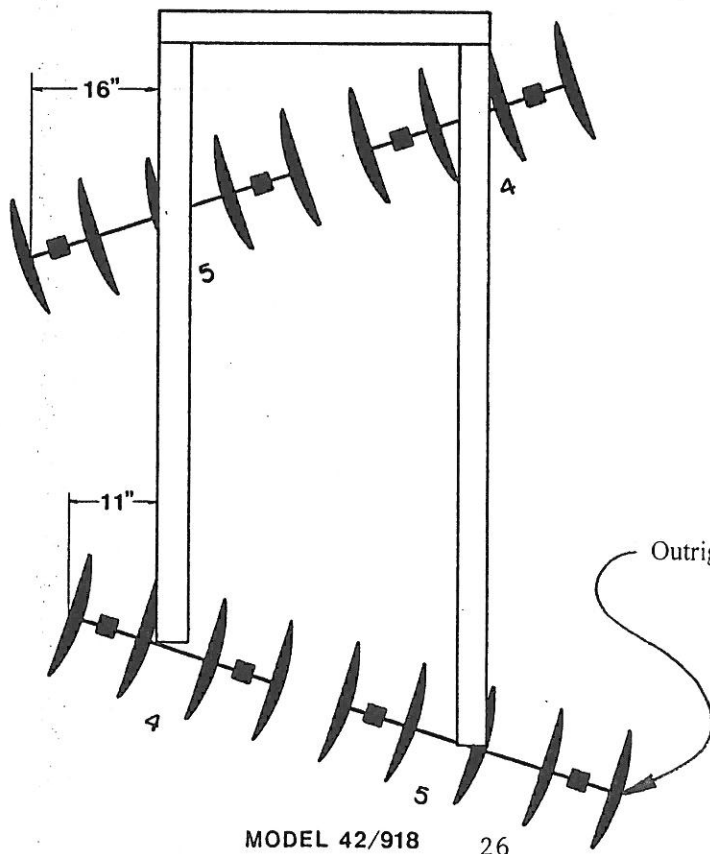

72" GANG BEAMS

MODEL 42/918
TUBE HANGERS

26

FRONT

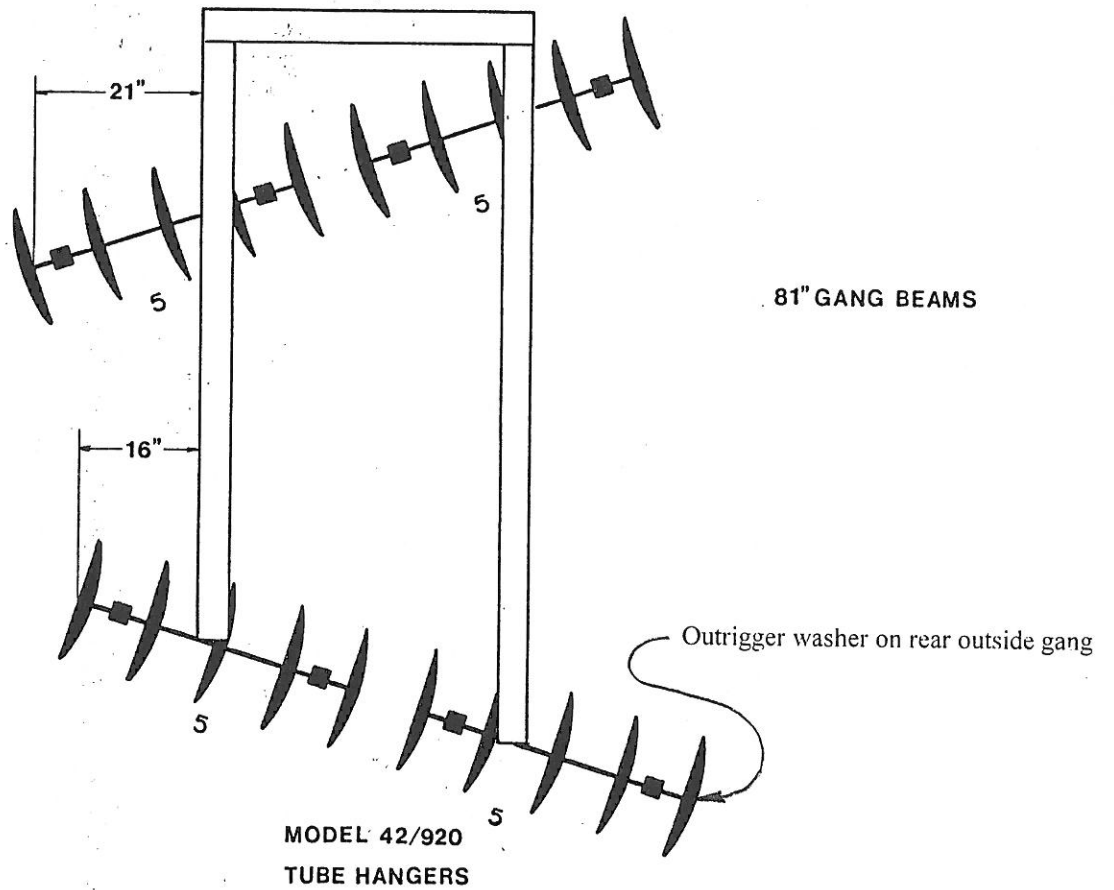

FRONT

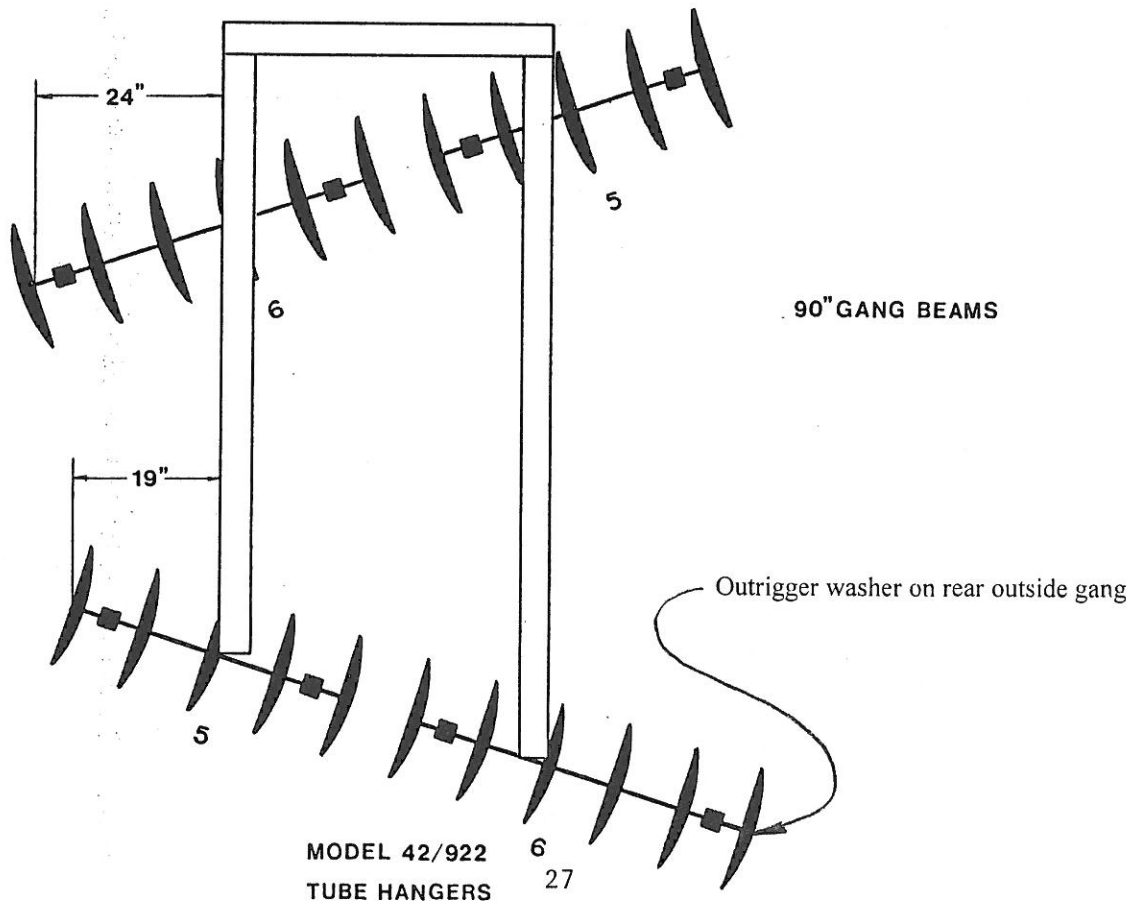

FRONT

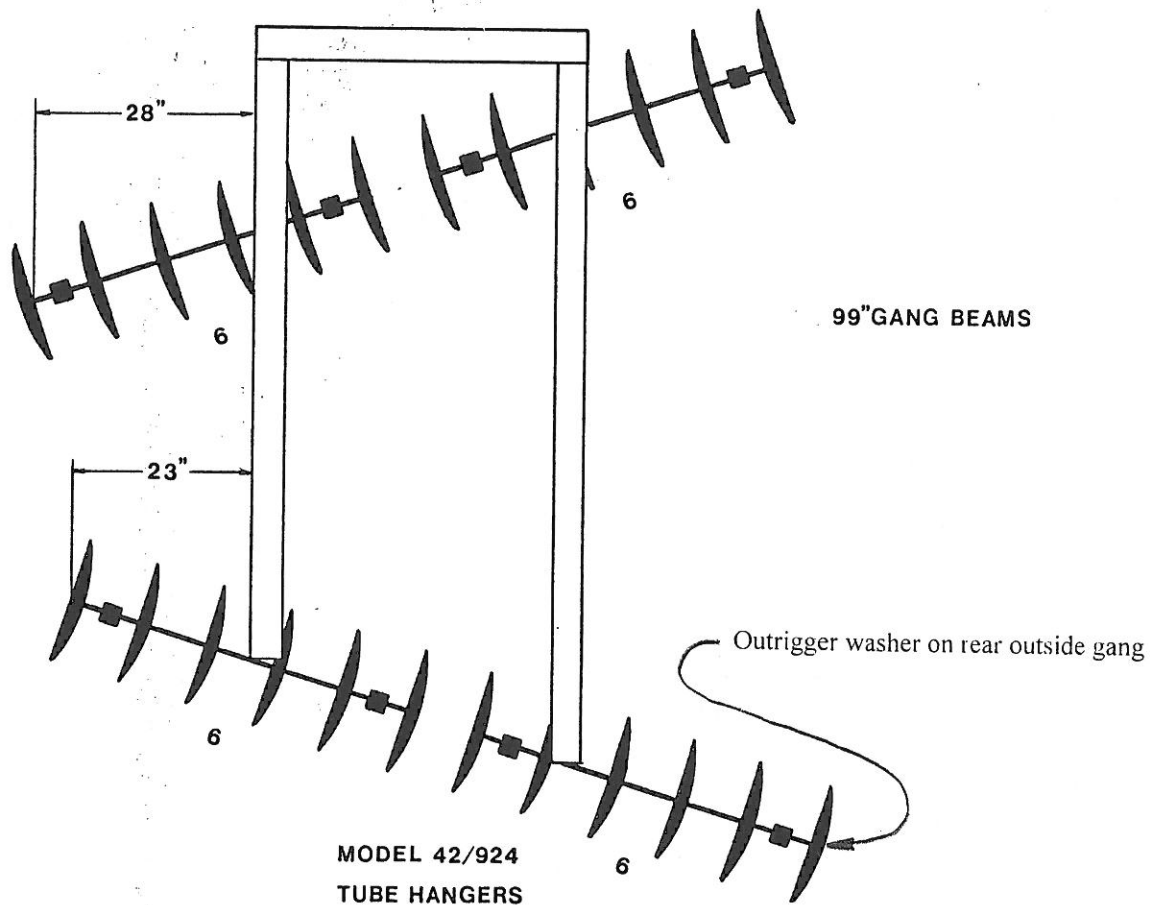

MODEL 42/924
TUBE HANGERS

FRONT

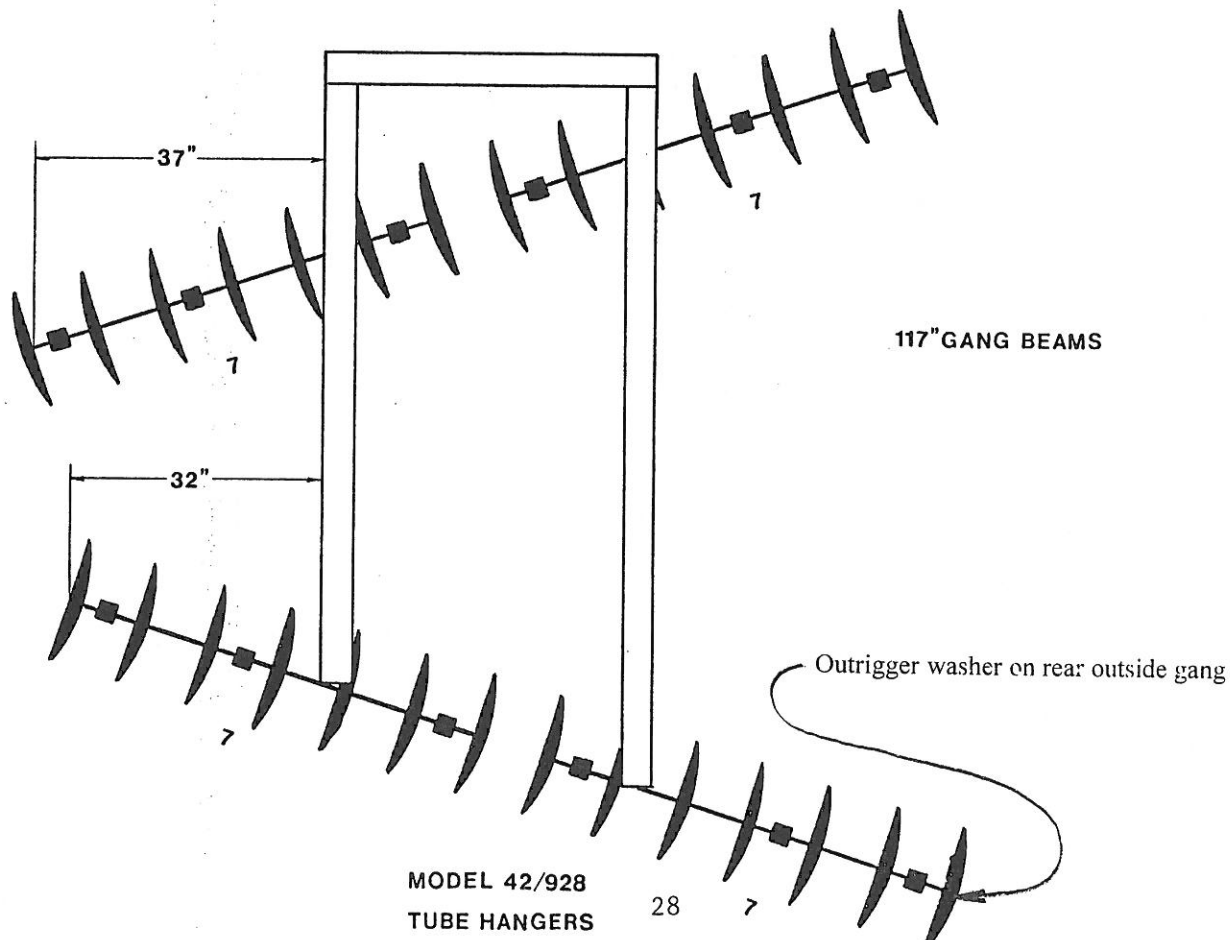

MODEL 42/928
TUBE HANGERS

28

7

FRONT

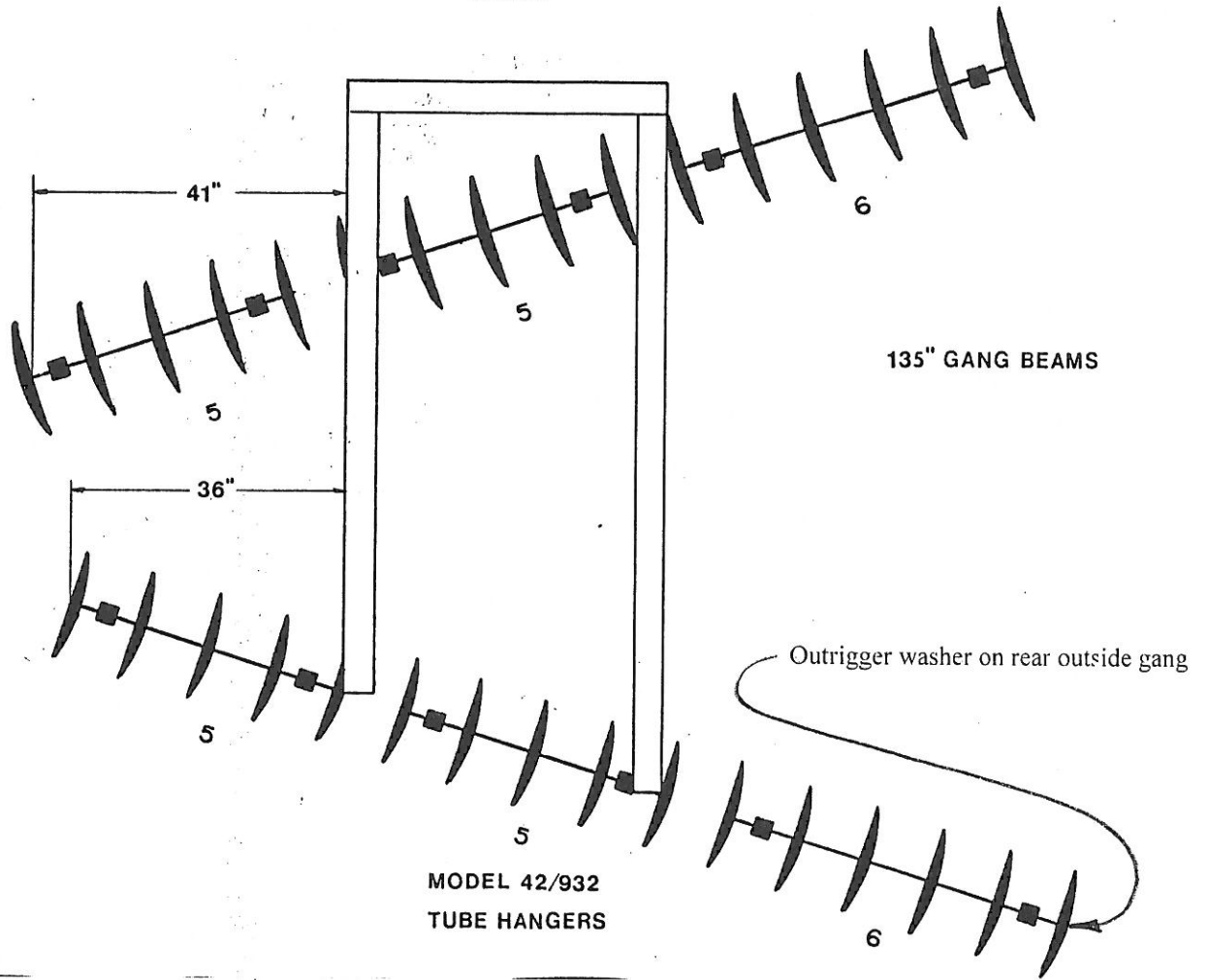

FRONT

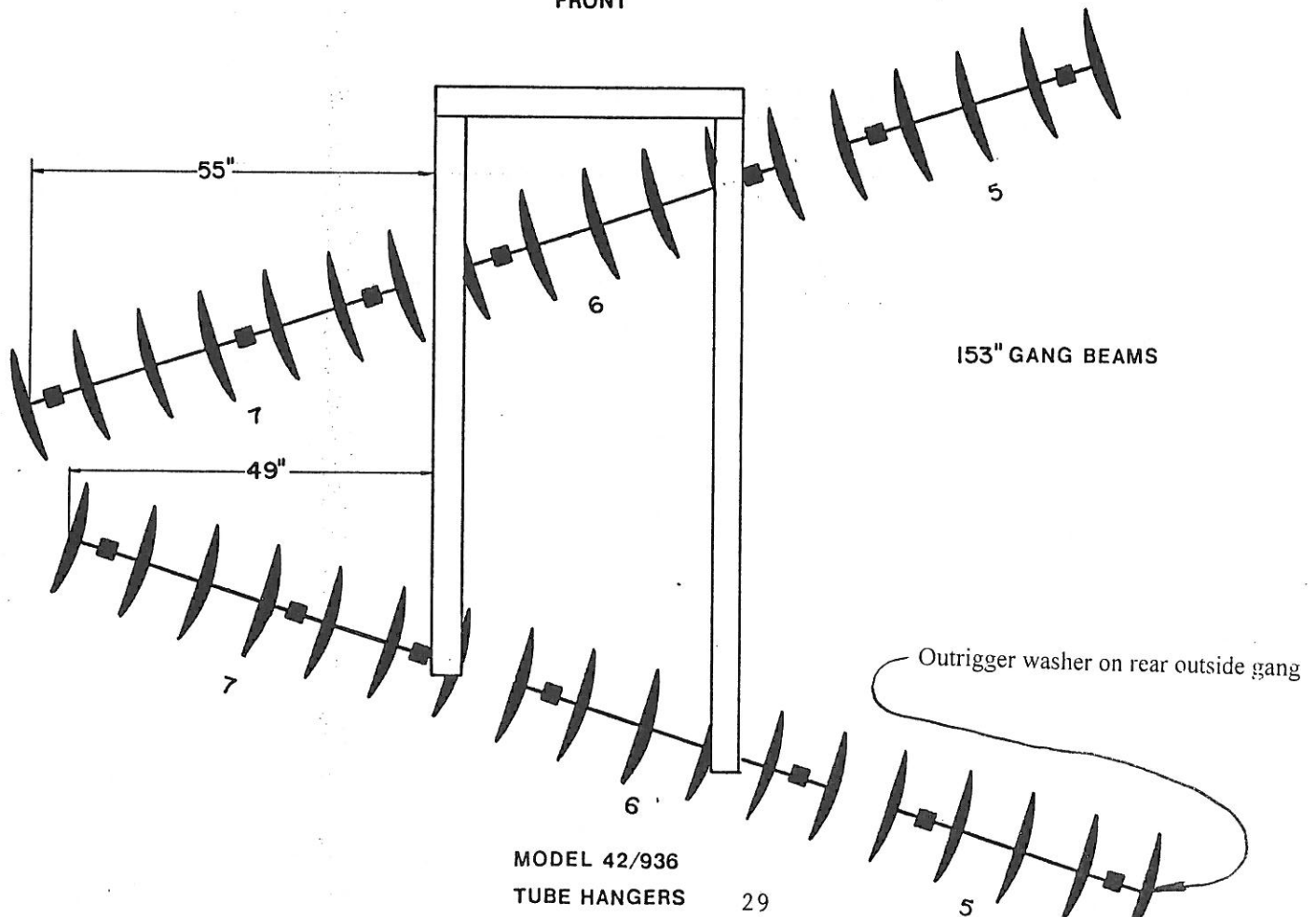

FRONT

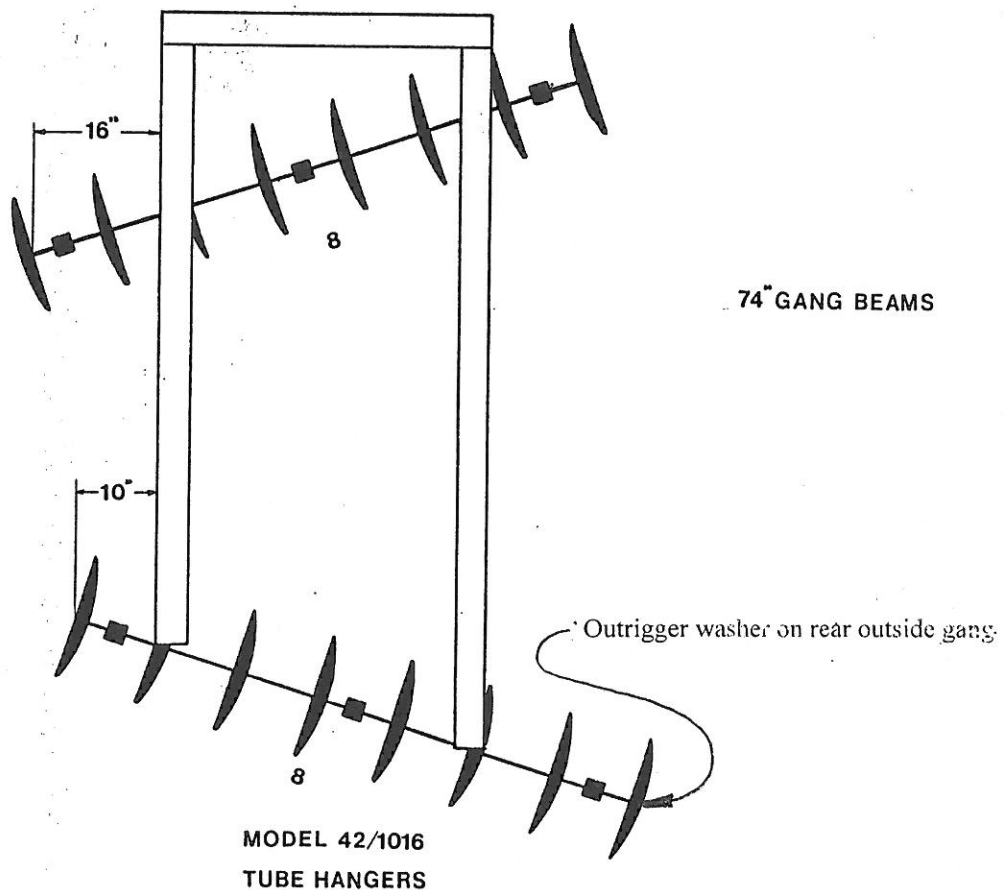

FRONT

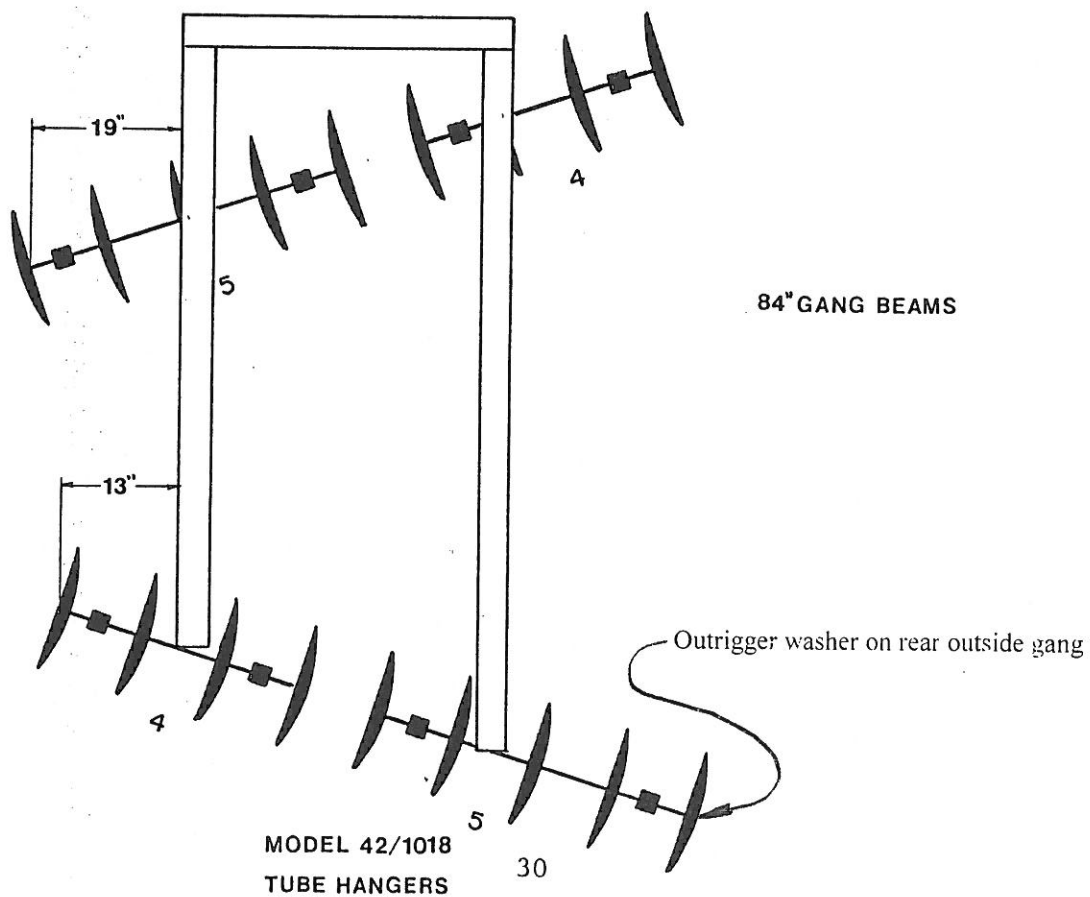

FRONT

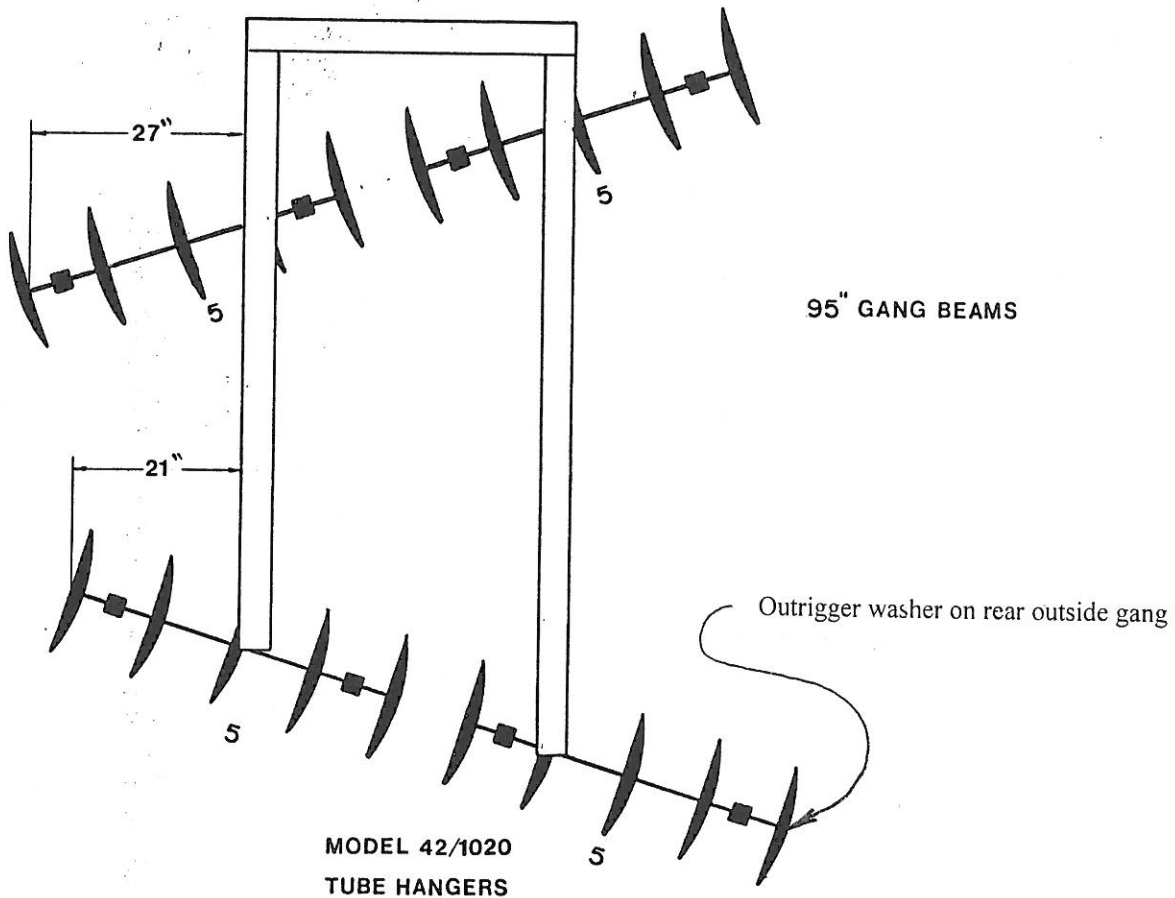

FRONT

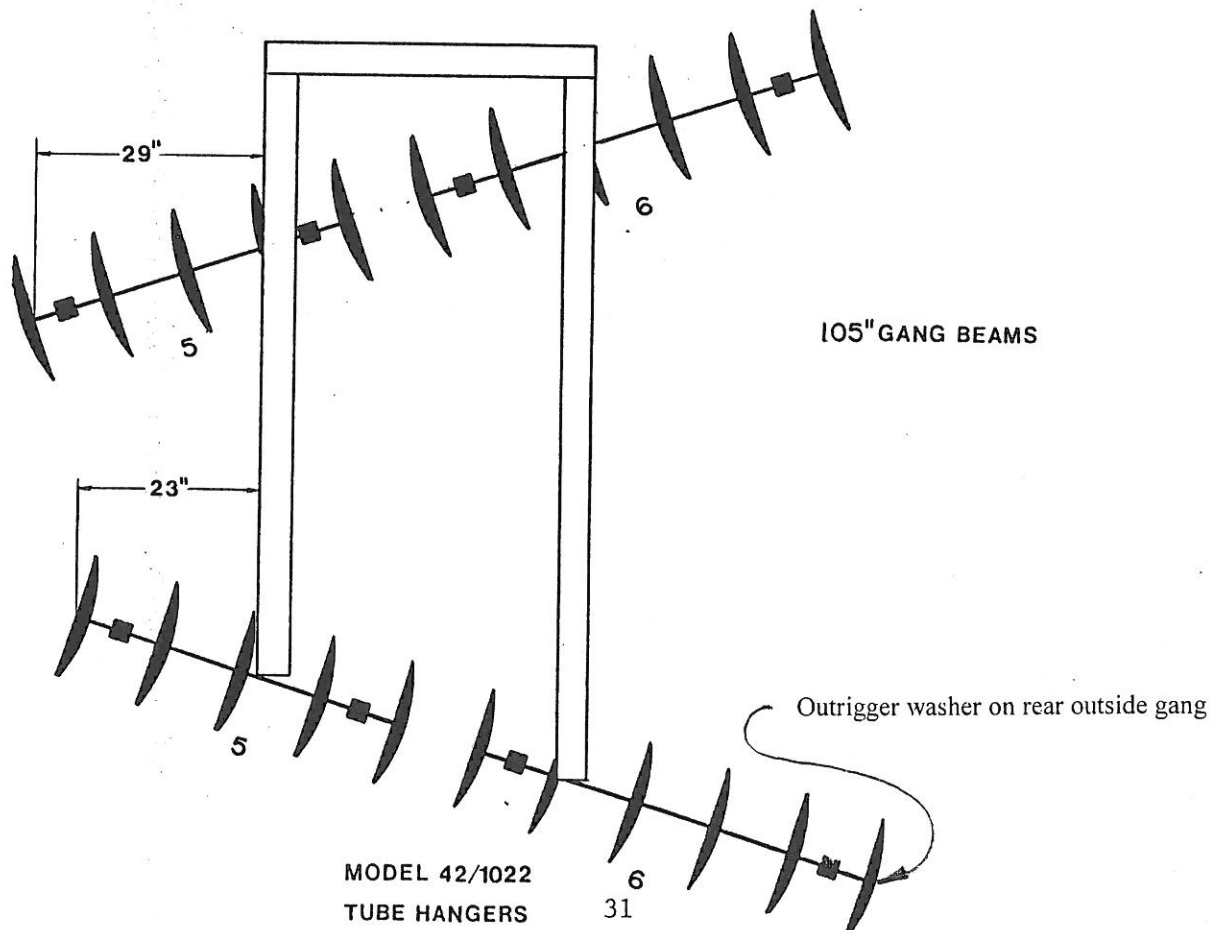

FRONT

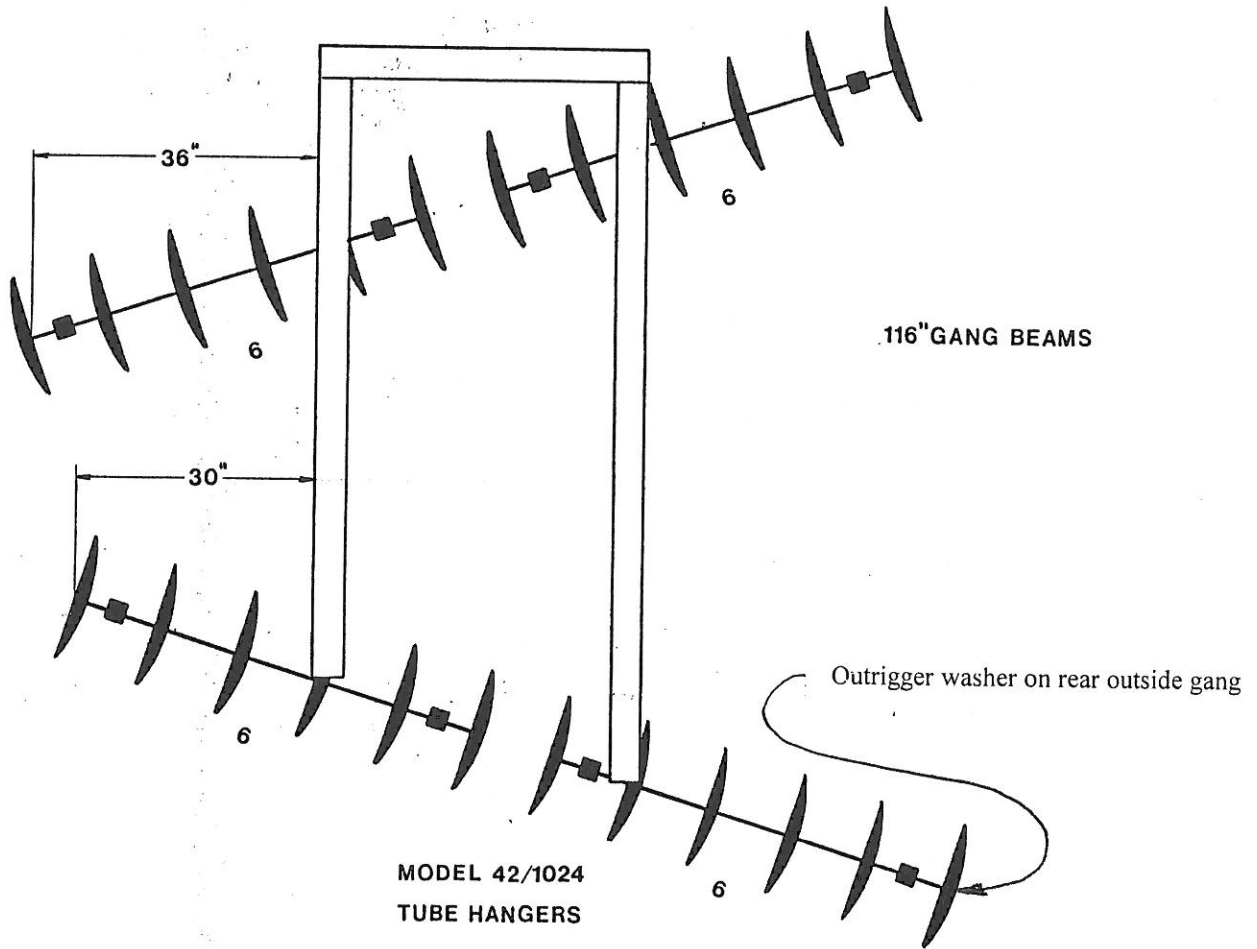

FRONT

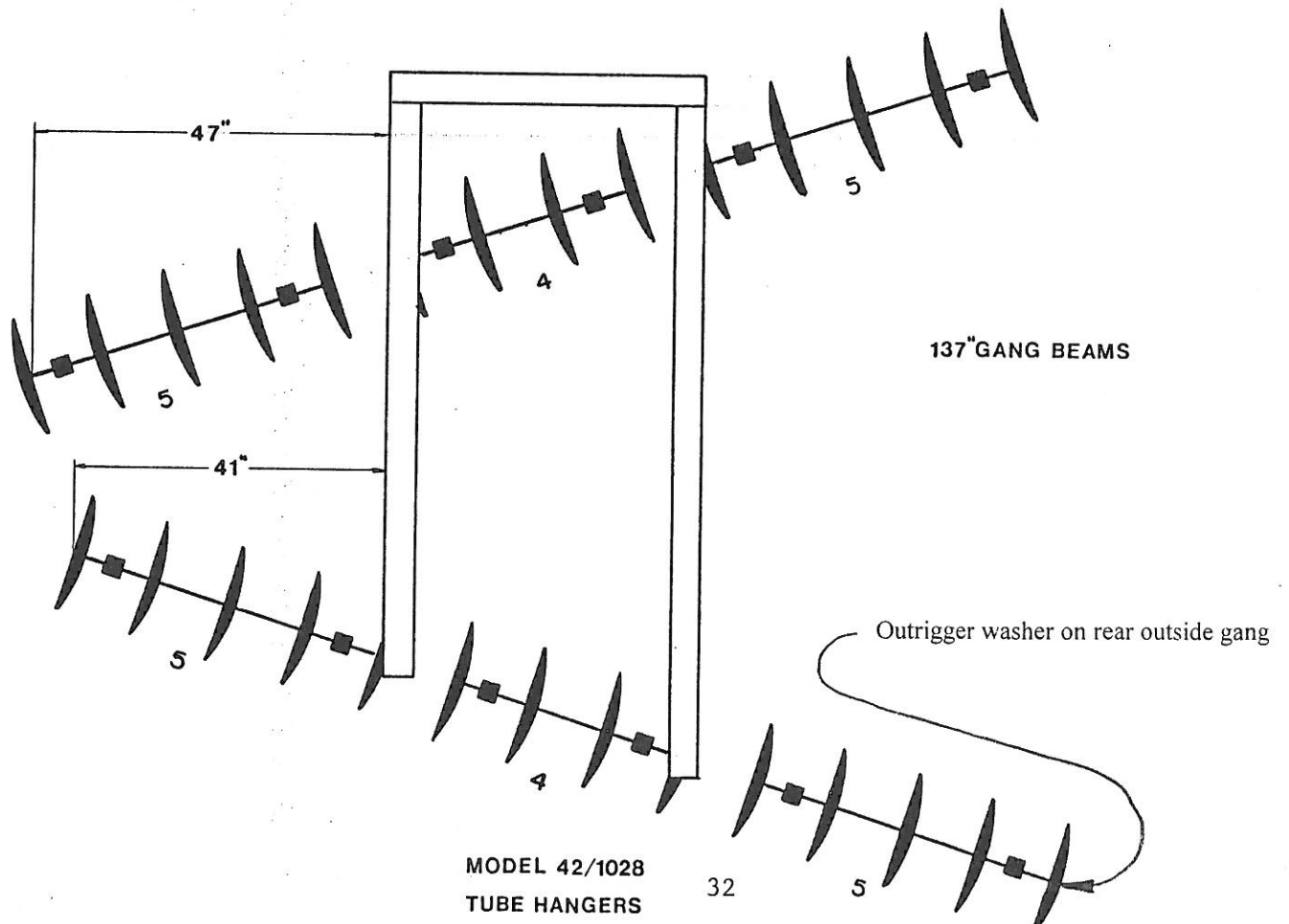

FRONT

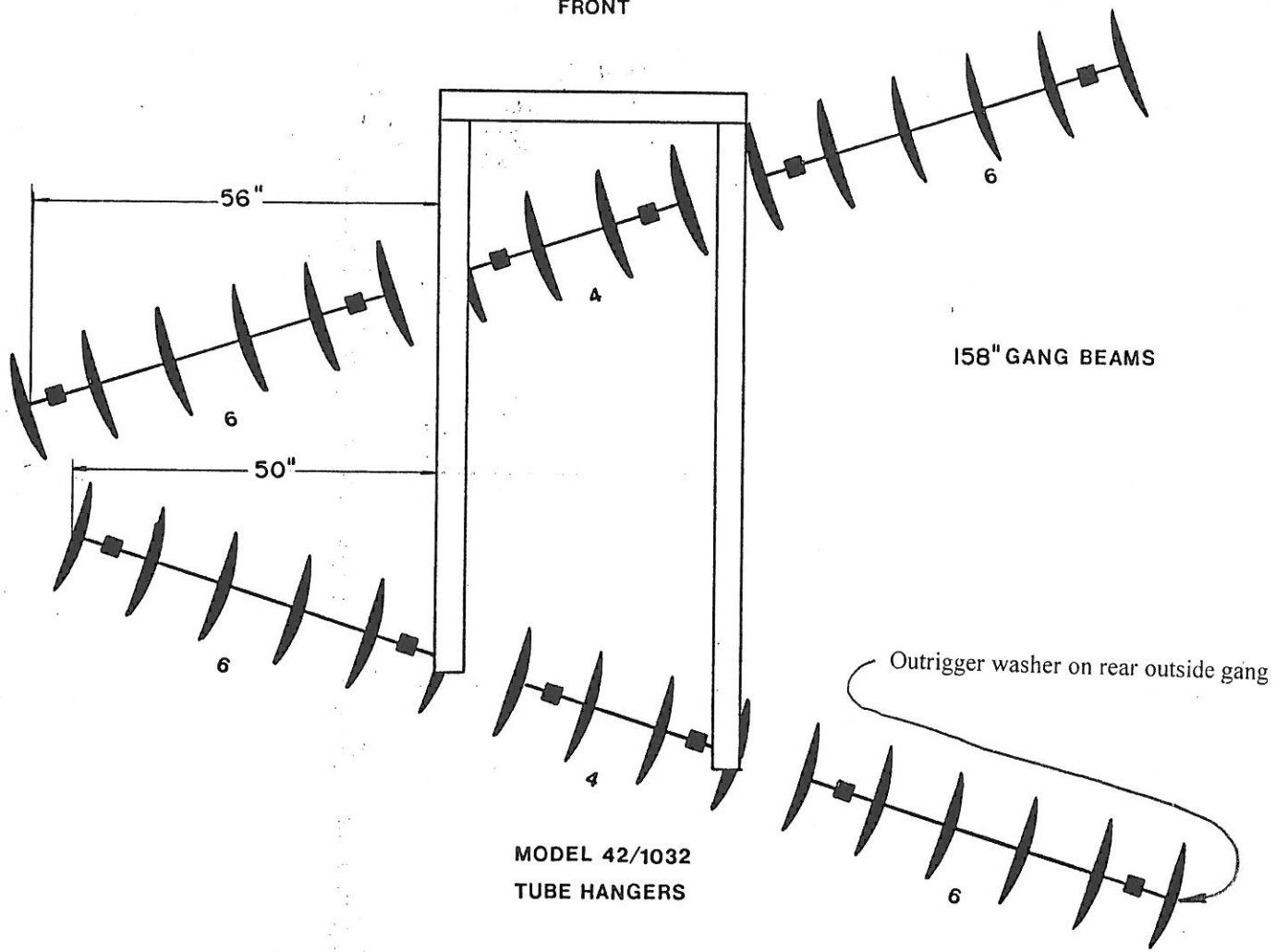

MODEL 42/1032
TUBE HANGERS

SAFETY DECAL PLACEMENT

****NOTE:** If safety decals have been damaged, removed, or become illegible, new decals must be applied. New decals are available from your distributor or dealer parts department or the factory.



WARNING

Before operating, study operator's manual safety instruction, and read all safety signs on this implement. Observe all state and federal laws before transporting down public roads. Use proper safety chains and tow implement at a maximum speed of 18 mph.

12589



DANGER

To avoid death or major injury stand clear when gangs are raised or lowered!
Mechanical or Hydraulic problems can allow the gangs to fall rapidly.

12592

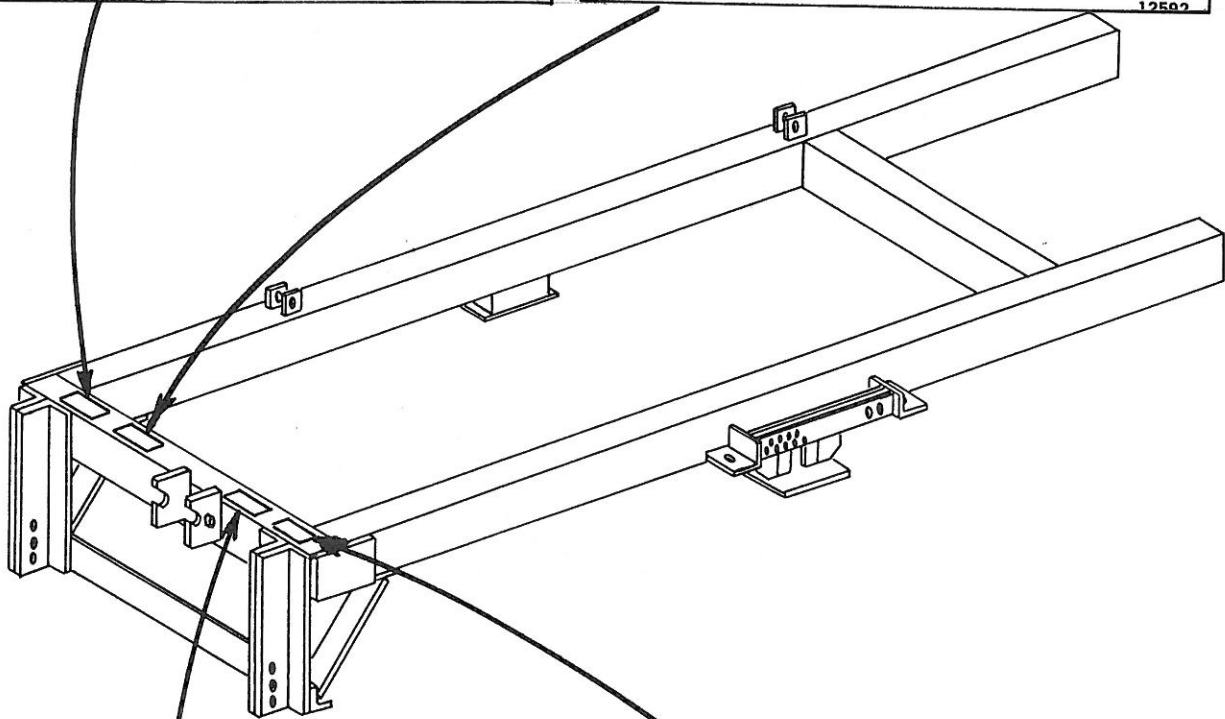

WARNING

FALLING BLADE HAZARD

- Can cause serious injury or death.
- Keep hands and feet from under raised blade.

12595



WARNING

Keep hands, fingers, and feet clear during adjustment and operation. Injury or dismemberment may occur if not careful!

12588

